

1.0 INTRODUCTION

1.1 SUMMARY OF TEST PROGRAM

General Motors LLC contracted Montrose Air Quality Services, LLC (Montrose) to perform a compliance emissions test program on their Landfill Gas-Fired Reciprocating Internal Combustion Engine (RICE) No. 1 (EUENGINE1) and RICE No. 3 (EUENGINE3). at the General Motors LLC - Orion Assembly (State Registration No. B7227) facility located in Lake Orion, Michigan. The tests were conducted to satisfy the emissions testing requirements pursuant to Michigan Department of Environment, Great Lakes, and Energy (EGLE) Permit No. MI-ROP-B7227-2020 and 40 CFR Part 60 Subpart JJJJ.

The specific objectives were to:

- Verify the emissions of nitrogen oxide (NO_x as NO₂), carbon monoxide (CO), and VOC (total gaseous nonmethane organic (TGNMO)) from EUENGINE1 and EUENGINE3
- Conduct the test program with a focus on safety

Montrose performed the tests to measure the emission parameters listed in Table 1-1.

**TABLE 1-1
 SUMMARY OF TEST PROGRAM**

Test Date(s)	Unit ID/ Source Name	Activity/ Parameters	Test Methods	No. of Runs	Duration (Minutes)
10/29/2020	EUENGINE1	Velocity/Volumetric Flow Rate	EPA 1 & 2	3	~10
10/29/2020	EUENGINE1	O ₂ , CO ₂	EPA 3A	3	60
10/29/2020	EUENGINE1	Moisture	EPA 4	3	60
10/29/2020	EUENGINE1	NO _x	EPA 7E	3	60
10/29/2020	EUENGINE1	CO	EPA 10	3	60
10/29/2020	EUENGINE1	TGO, CH ₄	EPA 25A	3	60
10/29/2020	EUENGINE3	Velocity/Volumetric Flow Rate	EPA 1 & 2	3	~10
10/29/2020	EUENGINE3	O ₂ , CO ₂	EPA 3A	3	60
10/29/2020	EUENGINE3	Moisture	EPA 4	3	60
10/29/2020	EUENGINE3	NO _x	EPA 7E	3	60

General Motors LLC - Orion Assembly (SRN B7227)
2020 Compliance Emissions Test Report

10/29/2020	EUENGINE3	CO	EPA 10	3	60
10/29/2020	EUENGINE3	TGO, CH ₄	EPA 25A	3	60

To simplify this report, a list of Units and Abbreviations is included in Appendix C.1. Throughout this report, chemical nomenclature, acronyms, and reporting units are not defined. Please refer to the list for specific details.

This report presents the test results and supporting data, descriptions of the testing procedures, descriptions of the facility and sampling locations, and a summary of the quality assurance procedures used by Montrose. The average emission test results are summarized and compared to their respective permit limits in Tables 1-2 and 1-3. Detailed results for individual test runs can be found in Section 4.0. All supporting data can be found in the appendices.

The testing was conducted by the Montrose personnel listed in Table 1-4 on October 29, 2020. The tests were conducted according to the test plan (protocol) that was submitted to and received by EGLE on September 3, 2020 and approved on September 24, 2020.

**TABLE 1-2
 SUMMARY OF AVERAGE COMPLIANCE RESULTS -
 EUENGINE1
 OCTOBER 29, 2020**

Parameter/Units	Average Results	Allowable Limits
Nitrogen Oxides (as NO₂)		
g/hp-hr	0.45	2.0
lb/hr	2.21	2.97
Carbon Monoxide (CO)		
g/hp-hr	2.22	3.5
lb/hr	10.9	17.3
VOC (TGNMO), as propane		
g/hp-hr	0	1.0
lb/hr	0	2.8

**TABLE 1-3
 SUMMARY OF AVERAGE COMPLIANCE RESULTS -
 EUENGINE3
 OCTOBER 29, 2020**

Parameter/Units	Average Results	Allowable Limits
Nitrogen Oxides (as NO₂)		
g/hp-hr	0.5	2.0
lb/hr	2.47	2.97
Carbon Monoxide (CO)		
g/hp-hr	2.11	3.5
lb/hr	10.4	17.3
VOC (TGNMO), as propane		
g/hp-hr	0	1.0
lb/hr	0	2.8

RECEIVED

DEC 21 2020

AIR QUALITY DIVISION

1.2 KEY PERSONNEL

A list of project participants is included below:

Facility Information

Source Location:	General Motors LLC - Orion Assembly 4555 Giddings Lake Orion, MI 48359	
Project Contact:	Kim Crame	Jessica Alderton
Role:	Sr. Environmental Engineer	Sr. Environmental Engineer
Company:	General Motors LLC	General Motors LLC
Telephone:	248-941-5305	586-863-8490
Email:	Kim.crame@gm.com	Jessica.alderton@gm.com

Agency Information

Regulatory Agency: EGLE
Contact: Regina Angelotti
Telephone: 313-418-0895
Email: angellottir1@michigan.gov

Testing Company Information

Testing Firm: Montrose Air Quality Services, LLC
Contact: Matthew Young
Title: District Manager
Telephone: 248-548-8070
Email: myoung@montrose-env.com

General Motors LLC - Orion Assembly (SRN B7227)
2020 Compliance Emissions Test Report

Test personnel and observers are summarized in Table 1-4.

**TABLE 1-4
TEST PERSONNEL AND OBSERVERS**

Name	Affiliation	Role/Responsibility
Matthew Young	Montrose	District Manager, QI
Mike Nummer	Montrose	Field Technician
Scott Dater	Montrose	Field Technician
Kim Crame	General Motors LLC	Observer/Client Liaison/Test Coordinator
Jessica Alderton	General Motors LLC	Client Liaison
Regina Angellotti	EGLE	Observer

2.0 PLANT AND SAMPLING LOCATION DESCRIPTIONS

2.1 PROCESS DESCRIPTION, OPERATION, AND CONTROL EQUIPMENT

General Motors LLC - Orion Assembly Plant operates five landfill gas (LFG) RICE generators to produce electricity at the plant. Each engine generator is rated at 1600 kW electrical output (2242 bhp). The total combined maximum electrical output will be 8000 kW or 8 MW. The maximum heat input capacity for each engine is approximately 15 MMBtu/hr. The heat capacity of landfill gas is estimated at 500 btu/scf. GM's Orion Assembly Plant is located near two nonhazardous solid waste landfills and has access to the landfill gas. The engine generators are specifically designed to burn the landfill gas. The combined exhaust from all five engine generators vents through the existing powerhouse stack located at the plant. Two of the five LFG RICE generators (EUENGINE1 and EUENGINE3) were tested during this test event.

2.2 FLUE GAS SAMPLING LOCATIONS

Information regarding the sampling locations is presented in Table 2-1.

**TABLE 2-1
 SAMPLING LOCATIONS**

Sampling Location	Stack Inside Dimensions (in.)	Distance from Nearest Disturbance		Number of Traverse Points
		Downstream EPA "B" (in./dia.)	Upstream EPA "A" (in./dia.)	
EUENGINE1 Exhaust	15.5	120 / 7.7	58 / 3.7	Flow: 16 (4/port) Gaseous 3 Moisture: 1
EUENGINE3 Exhaust	15.5	120 / 7.7	36 / 2.3	Flow: 16 (4/port) Gaseous 3 Moisture: 1

Sample locations were verified in the field to conform to EPA Method 1. Acceptable cyclonic flow conditions were confirmed prior to testing using EPA Method 1, Section 11.4. See Appendices A.1 through A.3 for more information.

2.3 OPERATING CONDITIONS AND PROCESS DATA

Emission tests were performed while EUENGINE1 and EUENGINE3 were operating normally.

Plant personnel were responsible for establishing the test conditions and collecting all applicable unit-operating data. The process data that was provided is presented in Appendix B.

3.0 SAMPLING AND ANALYTICAL PROCEDURES

3.1 TEST METHODS

The test methods for this test program were presented previously in Table 1-1. Additional information regarding specific applications or modifications to standard procedures is presented below.

3.1.1 EPA Method 1, Sample and Velocity Traverses for Stationary Sources

EPA Method 1 is used to assure that representative measurements of volumetric flow rate are obtained by dividing the cross-section of the stack or duct into equal areas, and then locating a traverse point within each of the equal areas. Acceptable sample locations must be located at least two stack or duct equivalent diameters downstream from a flow disturbance and one-half equivalent diameter upstream from a flow disturbance.

3.1.2 EPA Method 2, Determination of Stack Gas Velocity and Volumetric Flow Rate (Type S Pitot Tube)

EPA Method 2 is used to measure the gas velocity using an S-type pitot tube connected to a pressure measurement device, and to measure the gas temperature using a calibrated thermocouple connected to a thermocouple indicator. Typically, Type S (Stausscheibe) pitot tubes conforming to the geometric specifications in the test method are used, along with an inclined manometer. The measurements are made at traverse points specified by EPA Method 1.

FIGURE 3-1
EPA METHOD 2 SAMPLING TRAIN

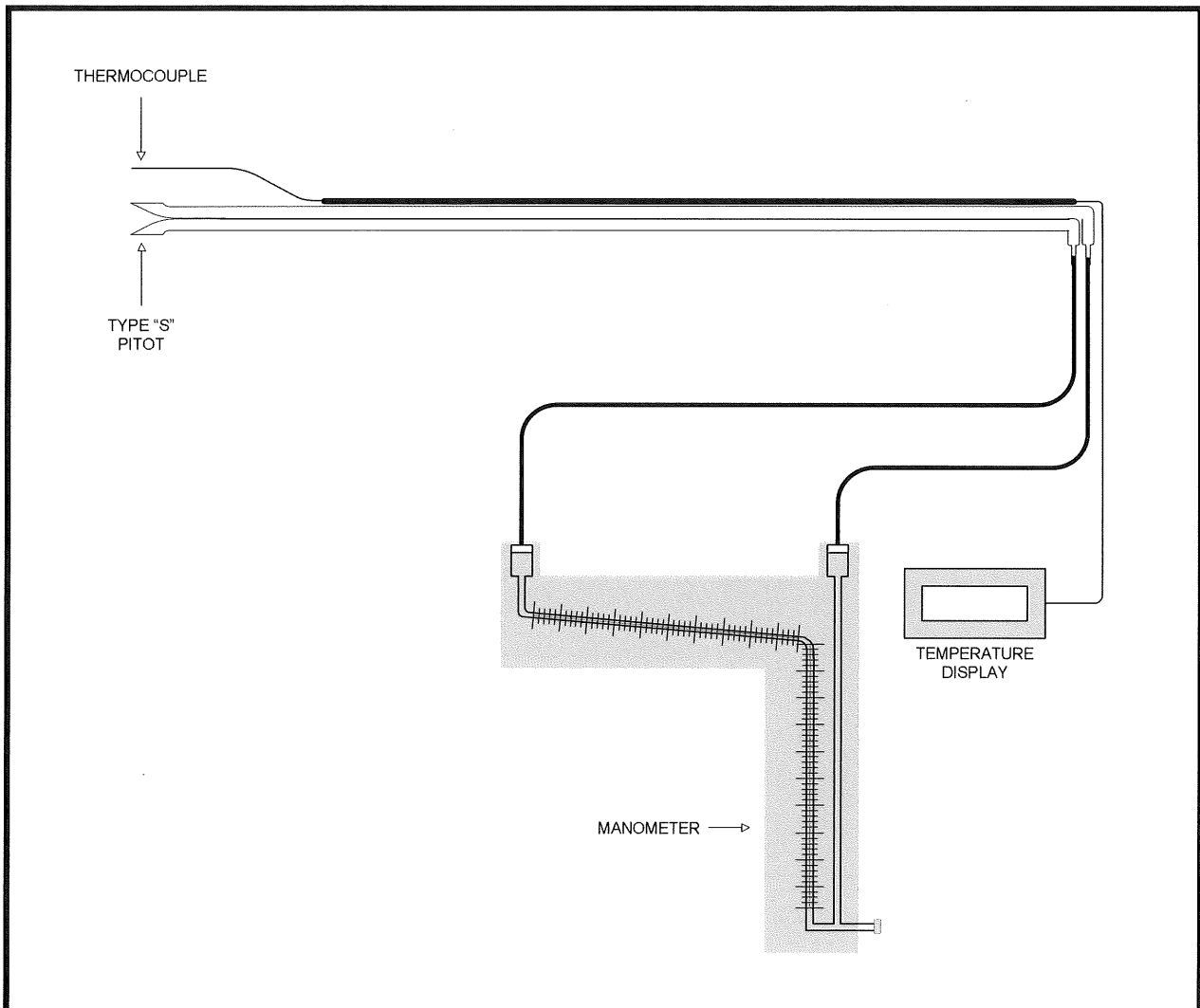

3.1.3 EPA Method 3A, Determination of Oxygen and Carbon Dioxide Concentrations in Emissions from Stationary Sources (Instrumental Analyzer Procedure)

EPA Method 3A is an instrumental test method used to measure the concentration of O_2 and CO_2 in stack gas. Conditioned gas is continuously or intermittently sampled and conveyed to analyzers that measure the concentration of O_2 and CO_2 . The performance requirements of the method must be met to validate data.

The sampling system is detailed in Figure 3-3.

3.1.4 EPA Method 4, Determination of Moisture Content in Stack Gas

EPA Method 4 is a manual, non-isokinetic method used to measure the moisture content of gas streams. Gas is sampled at a constant sampling rate through a probe and impinger train.

Moisture is removed using a series of pre-weighed impingers containing methodology-specific liquids and silica gel immersed in an ice water bath. The impingers are weighed after each run to determine the percent moisture.

The sampling system is detailed in Figure 3-2.

**FIGURE 3-2
 EPA METHOD 4 (DETACHED) SAMPLING TRAIN**

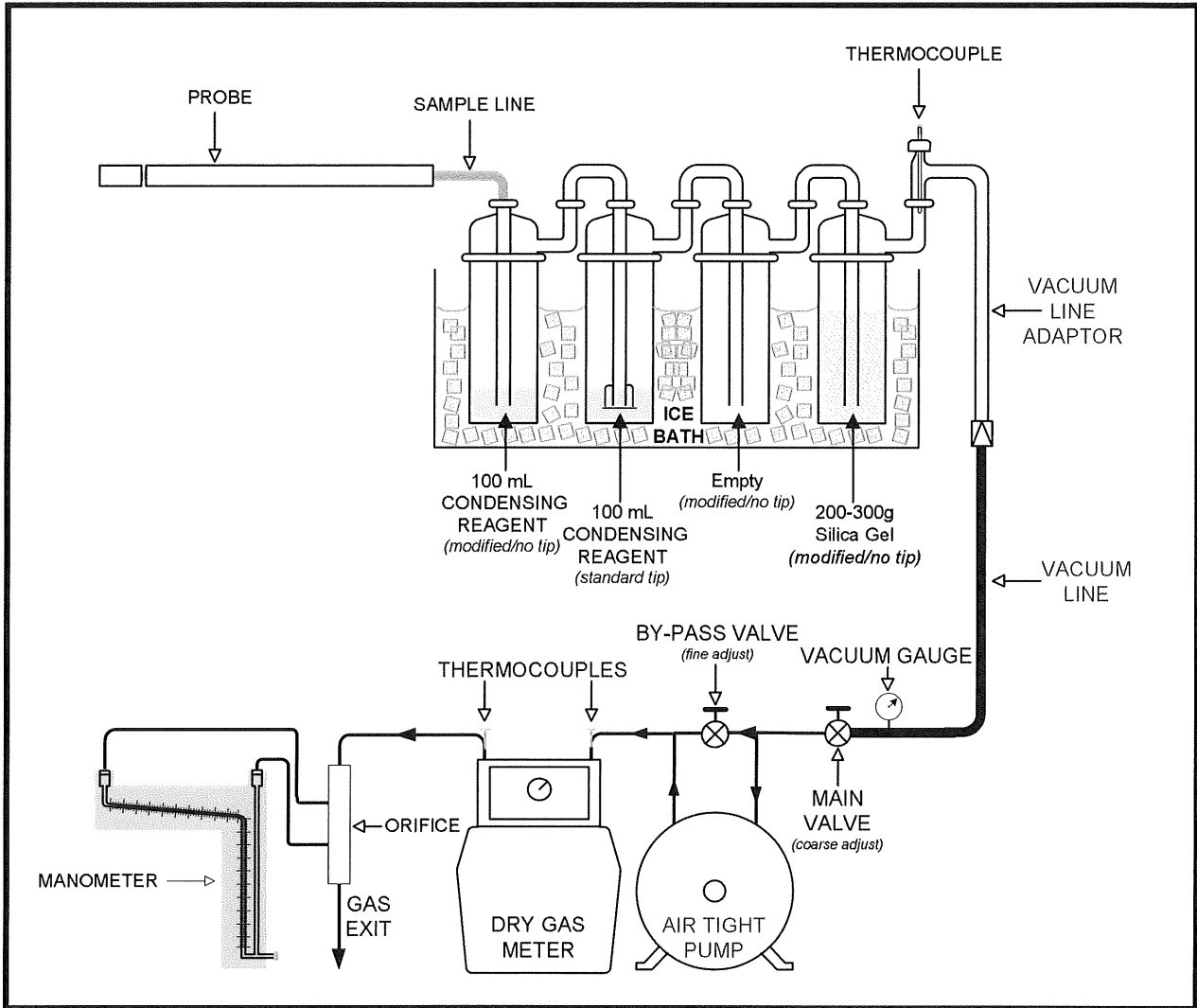

3.1.5 EPA Method 7E, Determination of Nitrogen Oxides Emissions from Stationary Source (Instrumental Analyzer Procedure)

EPA Method 7E is an instrumental test method used to continuously measure emissions of NO_x as NO₂. Conditioned gas is sent to an analyzer to measure the concentration of NO_x. NO and NO₂ can be measured separately or simultaneously together but, for the purposes of this method, NO_x is the sum of NO and NO₂. The performance requirements of the method must be met to validate the data.

The sampling system is detailed in Figure 3-3.

3.1.6 EPA Method 10, Determination of Carbon Monoxide Emissions from Stationary Sources (Instrumental Analyzer Procedure)

EPA Method 10 is an instrumental test method used to continuously measure emissions of CO. Conditioned gas is sent to an analyzer to measure the concentration of CO. The performance requirements of the method must be met to validate the data.

The sampling system is detailed in Figure 3-3.

3.1.7 EPA Method 25A, Determination of Total Gaseous Organic Concentration Using a Flame Ionization Analyzer

EPA Method 25A is an instrumental test method used to measure the concentration of THC in stack gas. A gas sample is extracted from the source through a heated sample line and glass fiber filter to a flame ionization analyzer (FIA). Results are reported as volume concentration equivalents of the calibration gas or as carbon equivalents.

The sampling system is detailed in Figure 3-3.

FIGURE 3-3
EPA METHODS 3A, 7E, 10, AND 25A SAMPLING TRAIN

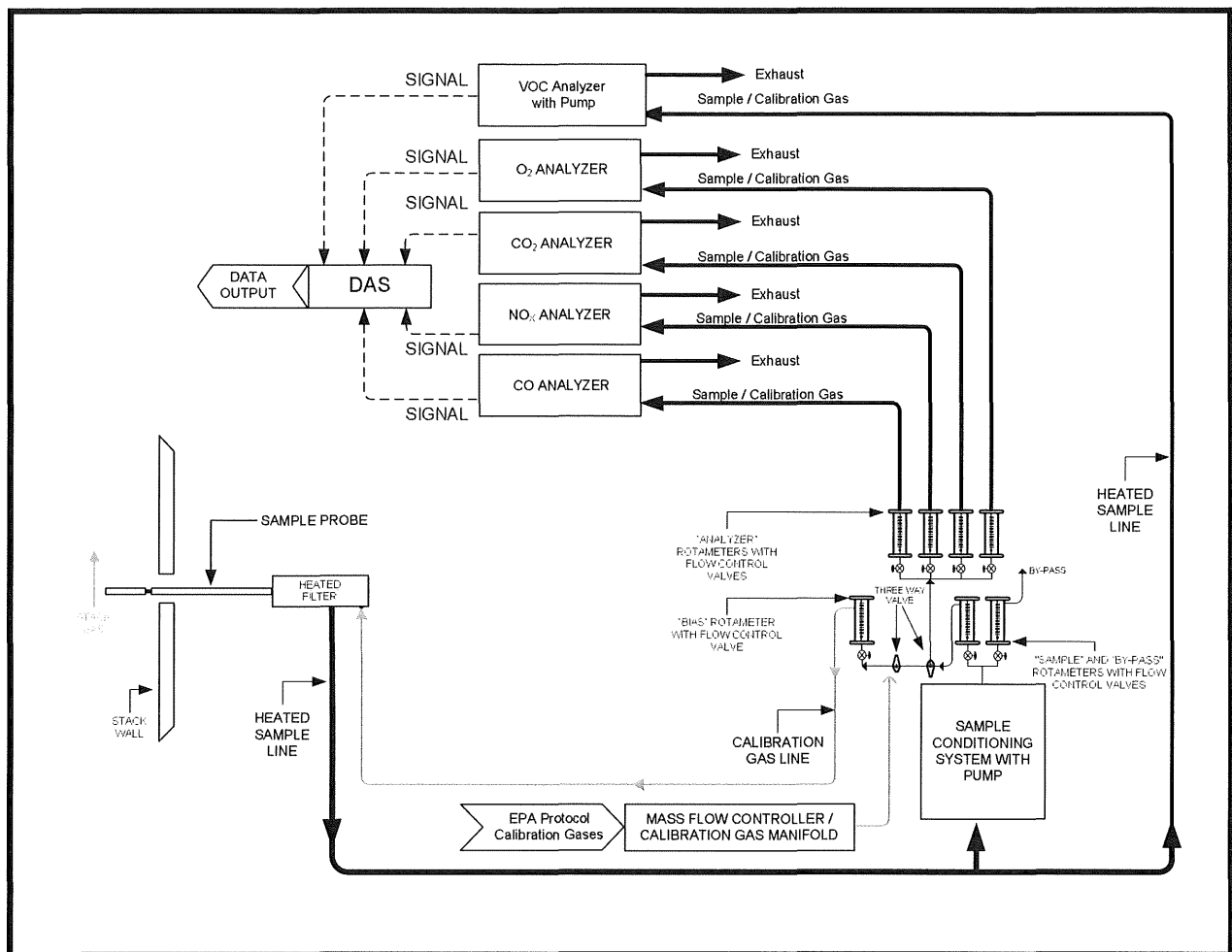

3.2 PROCESS TEST METHODS

The test plan did not require that process samples be collected during this test program; therefore, no process sample data are presented in this test report.

4.0 TEST DISCUSSION AND RESULTS

4.1 FIELD TEST DEVIATIONS AND EXCEPTIONS

No field deviations or exceptions from the test plan or test methods occurred during this test program

4.2 PRESENTATION OF RESULTS

The average results are displayed in Tables 1-2 and 1-3. The results of individual test runs performed are presented in Tables 4-1 and 4-2. Emissions are reported in units consistent with those in the applicable regulations or requirements. Additional information is included in the appendices as presented in the Table of Contents.

As shown in Tables 4-1 and 4-2 Engine Load, bhp-hr was calculated utilizing 2422 hp / 1600 kW provided by General Motors LLC - Orion Assembly Plant personnel.

As shown in Tables 4-1 and 4-2 the emissions and concentrations of VOC (TGNMO) were assigned a value of zero because the values were negative.

**TABLE 4-1
 NO_x (as NO₂), CO, AND VOC EMISSIONS RESULTS -
 EUENGINE1**

Run Number	1	2	3	Average
Date	10/29/2020	10/29/2020	10/29/2020	--
Time	08:12-09:12	09:42-10:42	11:05-12:05	--
Process Data				
Engine Load, kW-hr	1591	1589	1592	1590
Engine Load, bhp-hr	2229	2226	2231	2229
Flue Gas Parameters				
O ₂ , % volume dry	7.96	7.93	7.90	7.93
CO ₂ , % volume dry	11.6	11.6	11.7	11.7
flue gas temperature, °F	931	929	931	930
moisture content, % volume	12.1	12.0	12.4	12.1
volumetric flow rate, dscfm	4241	4437	4455	4377
Nitrogen Oxides				
ppmvd	72.3	69.6	69.3	70.4
lb/hr, as NO ₂	2.20	2.21	2.21	2.21
g/hp-hr, as NO ₂	0.45	0.45	0.45	0.45
Carbon Monoxide				
ppmvd	567	572	576	572
lb/hr	10.5	11.1	11.2	10.9
g/hp-hr	2.14	2.26	2.28	2.22
TGO, as propane				
ppmvd	497	494	501	498
Methane, as propane				
ppmvd	540	563	601	568
VOC (TGNMO) as propane*				
ppmvd	0	0	0	0
lb/hr	0	0	0	0
g/hp-hr	0	0	0	0

* Concentrations and emissions with a negative value are assigned a value of "0". See Section 4.2 for details.

**TABLE 4-2
 NO_x (AS NO₂), CO, AND VOC EMISSIONS RESULTS -
 EUENGINE3**

Run Number	1	2	3	Average
Date	10/29/2020	10/29/2020	10/29/2020	--
Time	12:44-13:44	14:05-15:05	15:25-16:25	--
Process Data				
Engine Load, kW-hr	1585	1585	1589	1586
Engine Load, bhp-hr	2221	2222	2226	2223
Flue Gas Parameters				
O ₂ , % volume dry	7.73	7.65	7.67	7.68
CO ₂ , % volume dry	11.9	11.9	11.9	11.9
flue gas temperature, °F	940	941	945	942
moisture content, % volume	12.6	12.4	12.8	12.6
volumetric flow rate, dscfm	4336	4149	4162	4214
Nitrogen Oxides				
ppmvd	79.2	81.2	85.6	82.0
lb/hr, as NO ₂	2.46	2.41	2.55	2.47
g/hp-hr, as NO ₂	0.50	0.49	0.52	0.50
Carbon Monoxide				
ppmvd	554	565	574	564
lb/hr	10.5	10.2	10.4	10.4
g/hp-hr	2.14	2.09	2.12	2.11
TGO, as propane				
ppmvd	478	449	444	457
Methane, as propane				
ppmvd	560	516	497	525
VOC (TGNMO) as propane*				
ppmvd	0	0	0	0
lb/hr	0	0	0	0
g/hp-hr	0	0	0	0

* Concentrations and emissions with a negative value are assigned a value of "0". See Section 4.2 for details.

5.0 INTERNAL QA/QC ACTIVITIES

5.1 QA/QC AUDITS

The meter box and sampling trains performed within the requirements of the respective methods. The post-test leak check and minimum metered volume met the applicable QA/QC criteria.

EPA Method 3A, 7E, and 10 calibration audits were all within the measurement system performance specifications for the calibration drift checks, system calibration bias checks, and calibration error checks.

EPA Method 25A FIA calibration audits were within the measurement system performance specifications for the calibration drift checks and calibration error checks.

The NO₂ to NO converter efficiency check of the analyzer was conducted per the procedures in EPA Method 7E, Section 8.2.4. The conversion efficiency met the criteria.

An EPA Method 205 field evaluation of the calibration gas dilution system was conducted. The dilution accuracy and precision QA specifications were met.

5.2 QA/QC DISCUSSION

All QA/QC criteria were met during this test program.

5.3 QUALITY STATEMENT

Montrose is qualified to conduct this test program and has established a quality management system that led to accreditation with ASTM Standard D7036-04 (Standard Practice for Competence of Air Emission Testing Bodies). Montrose participates in annual functional assessments for conformance with D7036-04 which are conducted by the American Association for Laboratory Accreditation (A2LA). All testing performed by Montrose is supervised on site by at least one Qualified Individual (QI) as defined in D7036-04 Section 8.3.2. Data quality objectives for estimating measurement uncertainty within the documented limits in the test methods are met by using approved test protocols for each project as defined in D7036-04 Sections 7.2.1 and 12.10. Additional quality assurance information is included in the report appendices. The content of this report is modeled after the EPA Emission Measurement Center Guideline Document (GD-043).