



EXECUTIVE SUMMARY

DTE Energy's Environmental Management and Resources (EM&R) Field Services Group performed 1st Quarter – 2020 Hydrogen Chloride (HCl) emissions testing on the exhaust of EU-Boiler#3 at the River Rouge Power Plant, located in River Rouge, Michigan. The testing was required by 40 CFR Part 63, Subpart UUUUU (Mercury and Air Toxics Standards - MATS) to document quarterly HCl stack emissions. The testing was conducted on March 5, 2020.

A summary of the emission test results are shown below:

**Emissions Testing Summary
River Rouge Power Plant
EU-Boiler#3**

Source	Date	Load (GMW)	HCl (lbs/MmBtu) ⁽¹⁾
EU-Boiler#3	3-5-20	162	0.0012

(1) MATS Limit 0.002 lbs/MMBtu

1.0 INTRODUCTION

DTE Energy's Environmental Management and Resources (EM&R) Field Services Group performed 1st Quarter – 2020 Hydrogen Chloride (HCl) emissions testing on the exhaust of EU-Boiler#3 at the River Rouge Power Plant, located in River Rouge, Michigan. The testing was required by the 40 CFR Part 63, Subpart UUUUU (Mercury and Air Toxics Standards - MATS) to document quarterly HCl stack emissions. The testing was conducted on March 5, 2020.

Testing was performed pursuant to ASTM Method D6348.

The fieldwork was performed in accordance with EPA Reference Methods and DTE Energy Intent to Test¹, which was approved in a letter by Mr. Tom Maza from the Michigan Department of Environment, Great Lakes & Energy (EGLE), dated January 20, 2017². The following DTE Energy personnel participated in the testing program: Mr. Thomas Snyder, Environmental Specialist, Mr. Mark Grigereit, Principal Engineer, and Mr. Fred Meinecke, Senior Engineering Technician. Mr. Snyder was the project leader. Ms. Tanecia Wilson, Associate Environmental Engineer at the plant, provided process coordination for the testing program.

2.0 SOURCE DESCRIPTION

The River Rouge Power Plant (RRPP), located at 1 Belanger Park Dr. River Rouge, Michigan, employs the use of one coal-fired boiler. EU-Boiler#3 is a Foster-Wheeler Boiler, nominally rated at 278 GMW. Particulate emissions from EU-Boiler#3 are controlled via a Wheelabrator-Fry electrostatic precipitator (ESP). The air pollution control equipment has a designed collection efficiency of 99.9%.

The boiler is equipped with a Dry Sorbent Injection (DSI) and Activated Carbon Injection (ACI) air quality control system. The DSI system is used to control acid gas, PM, PM10, PM2.5, and NOx emissions from the unit. Trona is received at the plant where inline mills further refine the Trona. The ACI system is used to control Mercury emissions.

Testing was performed on EU-Boiler#3 while operating at normal load conditions, per Subpart UUUUU.

¹ EGLE, Test Plan, Submitted January 5, 2017. (Attached-Appendix A)

² EGLE, Approval Letter, dated January 20, 2017. (Attached-Appendix A)

3.0 SAMPLING AND ANALYTICAL PROCEDURES

DTE Energy obtained emissions measurements in accordance with procedures specified in the USEPA *Standards of Performance for New Stationary Sources* or listed as an approved “*Other Test Method*”. The sampling and analytical methods used in the testing program are indicated in the table below:

Sampling Method	Parameter	Analysis
ASTM Method D6348	HCl, CO ₂ , and, Moisture Content	FTIR
USEPA Method 19	Emission Rate Calculations	Stoichiometric Calculations

3.1 MOISTURE (ASTM D6348)

3.1.1 Sampling Method

Moisture content in the exhaust was evaluated using ASTM D6348, “Measurement of Vapor Phase Organic Emissions by Extractive Fourier Transform Infrared (FTIR)”.

3.2 CARBON DIOXIDE (ASTM D6348)

3.2.1 Sampling Method

Carbon dioxide (CO₂) emissions were evaluated using ASTM D6348, “Measurement of Vapor Phase Organic Emissions by Extractive Fourier Transform Infrared (FTIR)”.

3.2.2 Sampling Train Calibration

The CO₂ analyzer was calibrated according to procedures outlined in USEPA Methods 3A and 7E. Zero, span, and mid range calibration gases were introduced directly into the analyzer to verify the instruments linearity, prior to sampling, and again at the completion of each test run. The CO₂ emissions were corrected for bias according to USEPA Method 7E.

3.3 HYDROGEN CHLORIDE (ASTM D6348)

3.3.1 Sampling Method

Hydrogen chloride and carbon dioxide emissions were evaluated using ASTM D6348, “Measurement of Vapor Phase Organic Emissions by Extractive Fourier Transform Infrared (FTIR)”. Single point sampling was performed. Triplicate 60-minute test runs

were performed. HCl emissions reported were corrected to analyte spike recovery (%R), according to Table 5 of Part 63 Subpart UUUUU.

The ASTM D6348 sampling system (Figure 2) consisted of the following:

- (1) Single-point sampling probe (located in the centroid of the exhaust stack)
- (2) Flexible heated PTFE sampling line
- (3) Air Dimensions Heated Head Diaphragm Pump
- (4) MKS MultiGas 2030 FTIR spectrometer
- (5) Appropriate calibration gases
- (6) Data Acquisition System

The FTIR was equipped with a temperature controlled, 5.11 meter multipass gas cell maintained at 191°C. Gas flows and sampling system pressures were monitored using a rotometer and pressure transducer. All data was collected at 0.5 cm⁻¹ resolution.

3.3.2 Sampling Train Calibration

The FTIR was calibrated according to procedures outlined in ASTM D6348. Direct measurements of Nitrogen (N₂), Hydrogen Chloride (HCl), Carbon Dioxide (CO₂), and Ethylene (C₂H₄) gas standards were made at the test location to confirm concentrations.

A calibration transfer standard (CTS) was analyzed before and after testing at each location. The concentration determined for all CTS runs were within ±5% of the certified value of the standard. Ethylene was passed through the entire system to determine the sampling system response time and to ensure that the entire sampling system was leak-free.

Nitrogen was purged through the sampling system at each test location to confirm the system was free of contaminants.

HCl spiking was performed to verify the ability of the sampling system to quantitatively deliver a sample containing HCl from the base of the probe to the FTIR. Analyte spiking assures the ability of the FTIR to quantify HCl in the presence of effluent gas.

As part of the spiking procedure, samples of effluent stack gas were measured to determine HCl concentrations to be used in the spike recovery calculations. The determined sulfur hexafluoride (SF₆) concentration in the spiked and unspiked samples was used to calculate the dilution factor of the spike and thus used to

calculate the concentration of the spiked HCl. The following equation illustrates the percent recovery calculation.

$$DF = \frac{SF_{6(\text{spike})}}{SF_{6(\text{direct})}} \quad (\text{Sec. A5.6 ASTM D6348})$$

$$CS = DF * Spike_{\text{dir}} + Unspike (1 - DF) \quad (\text{Sec. A5.7 ASTM D6348})$$

DF = Dilution factor of the spike gas

SF_{6(direct)} = SF₆ concentration measured directly in undiluted spike gas

SF_{6(spike)} = Diluted SF₆ concentration measured in a spiked sample

Spike_{dir} = Concentration of the analyte in the spike standard measured by the FTIR directly

CS = Expected concentration of the spiked samples

Unspike = Native concentration of analytes in unspiked samples

All analyte spikes were introduced using an instrument grade stainless steel rotometer. The spike target dilution ratio was 1:10 or less. All spike recoveries were within the ASTM D6348 allowance of ±30%. HCl emissions reported were corrected to analyte spike recovery (%R), according to Table 5 of Part 63 Subpart UUUUU.

3.3.3 Quality Control and Assurance

As part of the data validation procedure, reference spectra are manually fit to that of the sample spectra and a concentration is determined. The reference spectra are scaled to match the peak amplitude of the sample, thus providing a scale factor. The scale factor multiplied by the reference spectra concentration is used to determine the concentration value for the sample spectra. Sample pressure and temperature corrections are then applied to compute the final sample concentration. The manually calculated results are then compared with the software-generated results. The data is then validated if the two concentrations are within ± 5% agreement. If there is a difference greater than ± 5%, the spectra are reviewed for possible spectral interferences or any other possible causes that might lead to inaccurately quantified data. PRISM Analytical Technologies, Inc. validated the FTIR data. The data validation reports are located in Appendix C.

3.3.4 Data Reduction

Each spectrum was derived from the coaddition of 64 scans, with a new data point generated approximately every one minute. The emissions were recorded in parts per million (ppm) wet volume basis. The CO₂ emissions were recorded in percent (%) wet volume basis. The moisture content was recorded in percent (%).

4.0 OPERATING PARAMETERS

Unit 3 was tested for HCl emissions while burning a combination of low sulfur western coal, natural gas, and coke oven gas. Emission rates were proportionally calculated based on the percentage of each fuel burned during the testing.

The test program included the collection of boiler load and stack emissions CEMs data during each test run. Parameters recorded included gross Megawatts (GMW) and CEMs data (SO₂, NO_x, CO₂, and opacity). Additionally, dry sorbent injection rates (DSI) and activated carbon injection rates (ACI), in pounds per hour (lb/hr), are reported. Operational Data collected during the testing is presented in Appendix D.

During each day of emissions sampling, a representative coal sample was collected from the unit and analyzed for ultimate and proximate analysis, including % Sulfur, % Ash, and heat content. The results of the coal analysis was used to calculate an Fc value for each day of testing and used in the lb/MMBtu calculations. Results of the fuel analysis can be referred to in Appendix F. HCl emissions testing was performed at maximum normal operating load and representative of site specific normal operating conditions according to 40 CFR part 63.10007.

5.0 DISCUSSION OF RESULTS

Table 1 presents the HCl emission testing results from EU-Boiler#3. HCl emissions are presented in parts per million on a wet basis (ppm_w) and pounds per million BTU (lbs/MMBtu). The EU-Boiler#3 HCl emissions averaged 0.49ppm. EU-Boiler#3 demonstrated average HCl emissions below the Subpart UUUUU limit of 0.002 lb/MMBtu.

The auxiliary test data presented in the results table for each test includes the unit load in gross megawatts (GMW), DSI injection rate (lb/hr), ACI injection rate (lb/hr), and CO₂ concentration (%_{wet}).

6.0 CERTIFICATION STATEMENT

"I certify that I believe the information provided in this document is true, accurate, and complete. Results of testing are based on the good faith application of sound professional judgment, using techniques, factors, or standards approved by the Local, State, or Federal Governing body, or generally accepted in the trade."

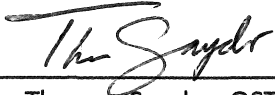

Mr. Thomas Snyder, QSTI

This report prepared by:

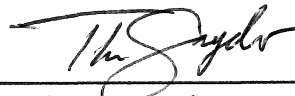

Mr. Thomas Snyder, QSTI
Environmental Specialist, Field Services Group
Environmental Management and Resources
DTE Energy Corporate Services, LLC

DTE

RESULTS TABLES



TABLE NO. 1
HYDROGEN CHLORIDE EMISSIONS TESTING RESULTS
River Rouge Power Plant - EU-BOILER#3
March 5, 2020

Test	Test Date	Test Time (DAHS)	Unit Load (GMW)	DSI Injection Rate (lb/hr)	ACI Injection Rate (lb/hr)	CO ₂ Concentration (% _{wet} , corrected)	HCl Concentration (ppmv _{wet})	HCl Emissions (lbs/MMBtu) ⁽¹⁾⁽²⁾
HCl-1	5-Mar-20	7:45-8:45	162	378	69	6.8	0.45	0.0011
HCl-2		9:03-10:03	161	201	69	6.9	0.45	0.0011
HCl-3		10:10-11:10	<u>162</u>	<u>0</u>	<u>69</u>	<u>6.9</u>	<u>0.57</u>	<u>0.0014</u>
<i>Average:</i>			<i>162</i>	<i>193</i>	<i>69</i>	<i>6.9</i>	<i>0.49</i>	<i>0.0012</i>

(1) Corrected to (%R)

(2) MATS Limit = 0.002 lb/MMBtu

DTE

FIGURES

Figure 1 – Sampling Location
River Rouge Power Plant – EU-BOILER#3
March 5, 2020

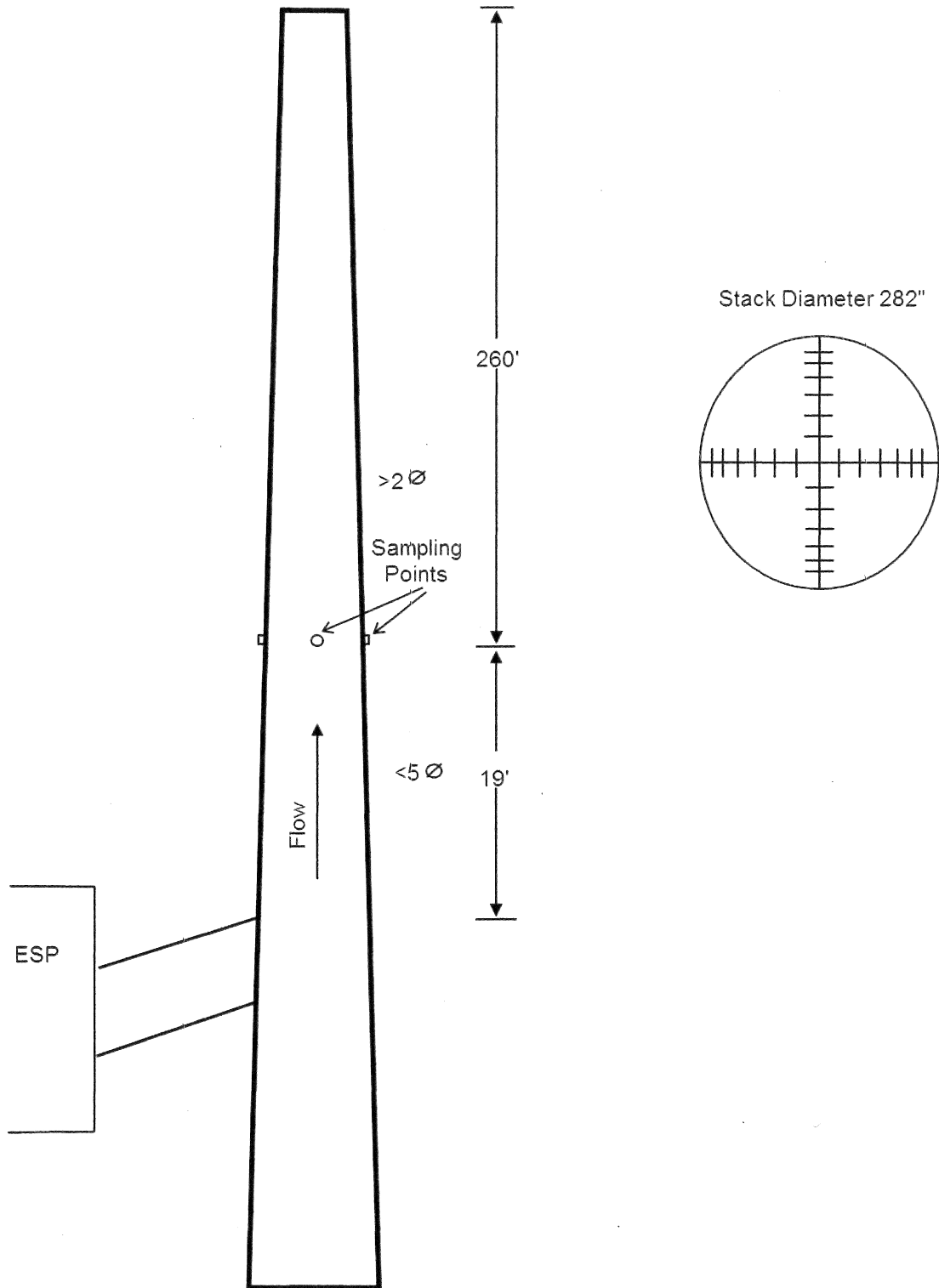

**Figure 2 – ASTM D6348
River Rouge Power Plant
March 5, 2020**

