

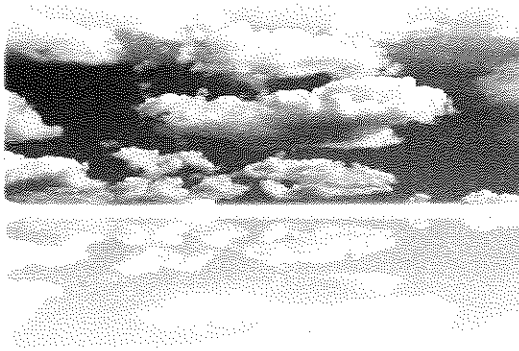

RECEIVED

AUG 23 2017

AIR QUALITY DIVISION



REPORT ON COMPLIANCE &
RATA TESTING

Detroit Refinery

CCR Interheater Stack (SV14-H4A)

Marathon Petroleum Company LP
1300 South Fort Street
Detroit, MI 48217
Client Reference No. 4101004604

CleanAir Project No. 13282-2
STAC Certificate No. 2007.002.0113.1217
Revision 0, Final Report
August 14, 2017

RECEIVED

AUG 23 2017

1. PROJECT OVERVIEW**AIR QUALITY DIVISION****Test Program Summary**

Marathon Petroleum Company LP (MPC) contracted CleanAir Engineering (CleanAir) to successfully complete testing on the CCR Interheater (EU14-CCRPLINTHR-S1) at the Detroit Refinery, located in Detroit, Michigan. The test program included the following objectives:

- Perform particulate matter (PM) and sulfuric acid mist (H₂SO₄) testing to demonstrate compliance with the Michigan Department of Environmental Quality (DEQ) Permit No. MI-ROP-A9831-2012c.
- Perform a relative accuracy test audit (RATA) on the facility's continuous emissions monitoring system (CEMS) for oxygen (O₂) and nitrogen oxide (NO_x).

A summary of the test program results is presented below. Section 2 Results provides a more detailed account of the test conditions and data analysis. Test program information, including the test parameters, on-site schedule and a project discussion, begins on page 2.

**Table 1-1:
Summary of Compliance Results**

Source	Constituent (Units)	Sampling Method	Average Emission	Permit Limit ¹
<i>CCR Interheater</i>				
	PM (lb/MMBtu)	USEPA M5	0.0008	0.0019
	PM ₁₀ (lb/MMBtu)	USEPA M5 / 202	0.0019	0.0076
	H ₂ SO ₄ (lb/MMBtu)	Draft ASTM CCM	6.4E-04	N/A

¹ Permit limits obtained from MDEQ Permit No. MI-ROP-A9831-2012c.

**Table 1-2:
Summary of RATA Results**

Source	Constituent (Units)	Reference Method	Relative Accuracy (%) ¹	Applicable Specification	Standard Used	Specification Limit
<i>CCR Interheater</i>						
	O ₂ (% dv)	USEPA M-3A	0.21	PS3	abs. diff.	± 1.0%
	NO _x (ppm @ 0%O ₂)	USEPA M-7E	2.3	PS2	% RM	20%

¹ Relative Accuracy is expressed in terms of comparison to the reference method (% RM), applicable standard (% appl. std.) or avg. absolute difference. The specific expression used depends on the specification limit cited.

Test Program Details

Parameters

The test program included the following emissions measurements:

- particulate matter (PM), assumed equivalent to filterable particulate matter (FPM) only
- total particulate matter less than 10 microns in diameter (PM₁₀), assumed equivalent to the sum of the following constituents:
 - filterable particulate matter (FPM)
 - condensable particulate matter (CPM)
- nitrogen oxides (NO_x)
- sulfuric acid mist (H₂SO₄)
- flue gas composition (e.g., O₂, CO₂, H₂O)
- flue gas temperature
- flue gas flow rate

Schedule

Testing was performed on June 28 and 29, 2017. The on-site schedule followed during the test program is outlined in Table 1-3.

**Table 1-3:
Test Schedule**

Run Number	Location	Method	Analyte	Date	Start Time	End Time
1	CCR Interheater Stack	USEPA Method 5/202	FPM/CPM	06/28/17	08:17	10:24
2	CCR Interheater Stack	USEPA Method 5/202	FPM/CPM	06/28/17	11:09	13:14
3	CCR Interheater Stack	USEPA Method 5/202	FPM/CPM	06/28/17	13:56	16:05
1	CCR Interheater Stack	USEPA Method 3A/7E	O ₂ /CO ₂ /NO _x	06/28/17	08:10	08:31
2	CCR Interheater Stack	USEPA Method 3A/7E	O ₂ /CO ₂ /NO _x	06/28/17	08:44	09:05
3	CCR Interheater Stack	USEPA Method 3A/7E	O ₂ /CO ₂ /NO _x	06/28/17	09:13	09:34
4	CCR Interheater Stack	USEPA Method 3A/7E	O ₂ /CO ₂ /NO _x	06/28/17	09:45	10:06
5	CCR Interheater Stack	USEPA Method 3A/7E	O ₂ /CO ₂ /NO _x	06/28/17	10:18	10:39
6	CCR Interheater Stack	USEPA Method 3A/7E	O ₂ /CO ₂ /NO _x	06/28/17	10:48	11:09
7	CCR Interheater Stack	USEPA Method 3A/7E	O ₂ /CO ₂ /NO _x	06/28/17	11:18	11:39
8	CCR Interheater Stack	USEPA Method 3A/7E	O ₂ /CO ₂ /NO _x	06/28/17	11:54	12:15
9	CCR Interheater Stack	USEPA Method 3A/7E	O ₂ /CO ₂ /NO _x	06/28/17	12:23	12:44
10	CCR Interheater Stack	USEPA Method 3A/7E	O ₂ /CO ₂ /NO _x	06/28/17	12:53	13:14
11	CCR Interheater Stack	USEPA Method 3A/7E	O ₂ /CO ₂ /NO _x	06/28/17	13:27	13:48
0	CCR Interheater Stack	Draft ASTM CCM	Sulfuric Acid	06/29/17	07:52	09:06
1	CCR Interheater Stack	Draft ASTM CCM	Sulfuric Acid	06/29/17	09:13	10:13
2	CCR Interheater Stack	Draft ASTM CCM	Sulfuric Acid	06/29/17	10:27	11:27
3	CCR Interheater Stack	Draft ASTM CCM	Sulfuric Acid	06/29/17	11:36	12:36

Discussion

Test Scope Synopsis

FPM & PM₁₀ Testing

A total of three (3) 120-minute EPA Method 5/202 test runs were performed. FPM/CPM emission results were calculated in units of pounds per million Btu (lb/MMBtu). The final result was expressed as the average of the three (3) valid runs.

For this test program, PM emission rate is assumed equivalent to FPM. PM₁₀ is assumed equivalent to the sum of FPM less than 10 micrometers (μm) in diameter (FPM₁₀) and CPM. The Method 5/202 sample train yields a front-half (FPM) result and a back-half (CPM) result. The total PM result (FPM plus CPM) from Method 5/202 can be used as a worst-case estimation of total PM₁₀ since Method 5 collects all FPM present in the flue gas (regardless of particle size).

O₂ & NO_x RATA Testing

Minute-average data points for O₂ and NO_x (dry basis) were collected over a period of 21 minutes for each run utilizing EPA Methods 3A and 7E. Relative accuracy was determined based on nine (9) of eleven (11) total runs conducted per procedures outlined in PS 2, Section 8.4.4.

Sampling occurred at the three (3) points specified in Section 8.1.3.2 of PS 2 during each run. The average result for each run was converted to identical units of measurement as the facility CEMs and compared for relative accuracy.

Run 1 was deemed invalid and not included in the final RA results. During Run 1, the CEMS probe was inadvertently positioned so that it was sampling from outside the threshold of the duct. Consequently, the sample was diluted and was unrepresentative of duct conditions. This is evident from the increase in O₂ concentrations and decrease in NO_x concentrations during the last four (4) minutes of the run.

H₂SO₄ Testing

H₂SO₄ emissions were determined referencing the Draft ASTM Controlled Condensation Method (CCM). Three (3) 60-minute Draft ASTM CCM test runs were performed. H₂SO₄ emission results were calculated in units of lb/MMBtu. The final results were expressed as the average of three (3) valid runs.

Prior to the first official test run, a 60-minute sample conditioning run (Run 0) was performed in order to minimize the absorption capacity of the front-half components of the sample train (upstream of the H₂SO₄-collecting portion of the sample train). The conditioning run was recovered in the same manner as the official test runs, but the condenser rinse and SAM filter were not analyzed.

Fuel Analysis

Emission results in units of dry volume-based concentration (lb/dscf, ppm_{dv}) were converted into units of pound per million BTU (lb/MMBtu) by calculating an oxygen-based fuel factor (F_d) for refinery gas per USEPA Method 19 specifications. The F_d factor was calculated from percent volume composition analytical data provided by MPC and tabulated heating values for each of the measured constituents.

Test Conditions

The unit was operated at the maximum normal operating capacity during each of the emissions compliance test runs and no less than 50% of the maximum normal operating capacity during RATA test runs. MPC was responsible for logging any relevant process-related data and providing it to CleanAir for inclusion in the test reports.

End of Section

2. RESULTS

This section summarizes the test program results. Additional results are available in the report appendices, specifically Appendix C Parameters.

**Table 2-1:
CCR Interheater Stack – FPM & PM₁₀ Emissions**

Run No.		1	2	3	Average
Date (2017)		Jun 28	Jun 28	Jun 28	
Start Time (approx.)		08:17	11:09	13:56	
Stop Time (approx.)		10:24	13:14	16:05	
Process Conditions					
P ₁	Fuel gas flow rate (Mscf/day)	2,860	2,843	2,801	2,835
P ₂	Feed rate (bpd)	20,995	21,000	21,004	21,000
F _d	Oxygen-based F-factor (dscf/MMBtu)	8,303	8,303	8,303	8,303
Gas Conditions					
O ₂	Oxygen (dry volume %)	6.2	6.7	6.3	6.4
CO ₂	Carbon dioxide (dry volume %)	8.4	8.1	8.5	8.3
T _s	Sample temperature (°F)	529	527	529	528
B _w	Actual water vapor in gas (% by volume)	14.1	13.9	14.0	14.0
Gas Flow Rate					
Q _a	Volumetric flow rate, actual (acfm)	44,200	42,800	41,500	42,800
Q _s	Volumetric flow rate, standard (scfm)	23,200	22,500	21,800	22,500
Q _{std}	Volumetric flow rate, dry standard (dscfm)	20,000	19,400	18,800	19,400
Sampling Data					
V _{mstd}	Volume metered, standard (dscf)	77.18	75.32	74.14	75.54
%I	Isokinetic sampling (%)	99.9	100.3	102.1	100.7
Laboratory Data					
m _n	Total FPM(g)	0.00297	0.00218	0.00217	
m _{CPM}	Total CPM(g)	0.00291	0.00299	0.00324	
m _{part}	Total particulate matter (as PM ₁₀)(g)	0.00588	0.00517	0.00541	
FPM Results					
C _{sd}	Particulate Concentration (lb/dscf)	8.49E-08	6.38E-08	6.45E-08	7.11E-08
E _{lb/hr}	Particulate Rate (lb/hr)	0.102	0.0743	0.0727	0.0829
E _{Fd}	Particulate Rate - F _d -based (lb/MMBtu)	0.001002	0.000780	0.000767	0.000850
CPM Results					
C _{sd}	Particulate Concentration (lb/dscf)	8.32E-08	8.76E-08	9.62E-08	8.90E-08
E _{lb/hr}	Particulate Rate (lb/hr)	0.100	0.102	0.108	0.103
E _{Fd}	Particulate Rate - F _d -based (lb/MMBtu)	0.00098	0.00107	0.00114	0.00107
Total Particulate Matter (as PM₁₀) Results					
C _{sd}	Particulate Concentration (lb/dscf)	1.68E-07	1.51E-07	1.61E-07	1.60E-07
E _{lb/hr}	Particulate Rate (lb/hr)	0.201	0.176	0.181	0.186
E _{Fd}	Particulate Rate - F _d -based (lb/MMBtu)	0.00198	0.00185	0.00191	0.00192

**Table 2-2:
 CCR Interheater Stack – O₂ (% dv) RATA**

Run No.	Start Time	Date (2017)	RM Data (%dv)	CEMS Data (%dv)	Difference (%dv)	Difference Percent
1 *	08:10	Jun 28	6.59	6.15	0.44	6.7%
2	08:44	Jun 28	5.90	6.11	-0.21	-3.6%
3	09:13	Jun 28	5.91	6.13	-0.22	-3.7%
4	09:45	Jun 28	5.87	6.12	-0.25	-4.3%
5	10:18	Jun 28	5.96	6.00	-0.04	-0.7%
6	10:48	Jun 28	5.73	5.86	-0.13	-2.3%
7	11:18	Jun 28	5.79	6.01	-0.22	-3.8%
8	11:54	Jun 28	5.73	5.99	-0.26	-4.5%
9	12:23	Jun 28	5.71	5.97	-0.26	-4.6%
10 *	12:53	Jun 28	5.70	5.99	-0.29	-5.1%
11	13:27	Jun 28	5.71	5.97	-0.26	-4.6%
Average			5.81	6.02	-0.21	-3.5%

Relative Accuracy Test Audit Results

Standard Deviation of Differences	0.075	
Confidence Coefficient (CC)	0.057	
t-Value for 9 Data Sets	2.306	
Avg. Abs. Diff. (%dv)	0.21	Limit 1.0

RM = Reference Method (CleanAir Data)

072517 135915

CEMS = Continuous Emissions Monitoring System (Marathon Petroleum Company Data)

RATA calculations are based on 9 of 11 runs. * indicates the excluded runs.

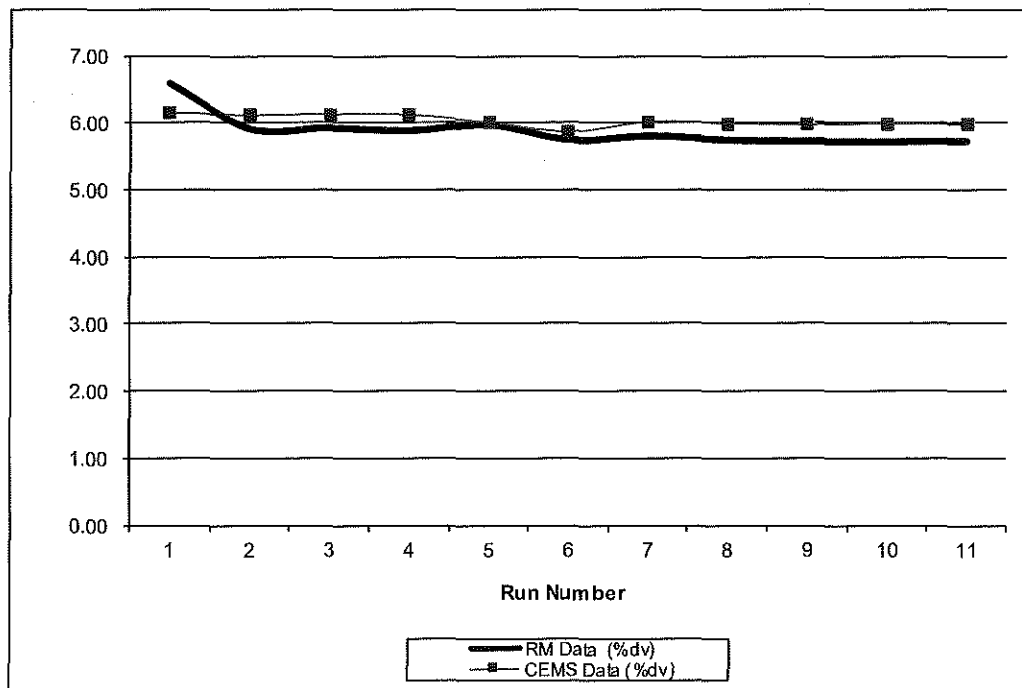

**Table 2-3:
 CCR Interheater Stack – NO_x (ppm @ 0% O₂) RATA**

Run No.	Start Time	Date (2017)	RM Data (ppm@0%O2)	CEMS Data (ppm@0%O2)	Difference (ppm@0%O2)	Difference Percent
1 *	08:10	Jun 28	31.8	35.2	-3.4	-10.7%
2	08:44	Jun 28	34.9	35.3	-0.4	-1.1%
3	09:13	Jun 28	34.5	34.8	-0.3	-0.9%
4	09:45	Jun 28	34.3	35.2	-0.9	-2.6%
5	10:18	Jun 28	34.3	34.1	0.2	0.6%
6	10:48	Jun 28	33.0	33.6	-0.6	-1.8%
7	11:18	Jun 28	33.8	34.6	-0.8	-2.4%
8	11:54	Jun 28	33.4	34.2	-0.8	-2.4%
9	12:23	Jun 28	32.8	33.4	-0.6	-1.8%
10 *	12:53	Jun 28	33.4	34.4	-1.0	-3.0%
11	13:27	Jun 28	34.0	34.6	-0.6	-1.8%
Average			33.9	34.4	-0.5	-1.6%

Relative Accuracy Test Audit Results

Standard Deviation of Differences	0.335	
Confidence Coefficient (CC)	0.258	
t-Value for 9 Data Sets	2.306	
Relative Accuracy (as % of RM)	2.3%	Limit 20.0%
Relative Accuracy (as % of Appl. Std.)	2.0%	10.0%
Appl. Std. = 40 ppm@0%O2		

RM = Reference Method (CleanAir Data)

072517 135915

CEMS = Continuous Emissions Monitoring System (Marathon Petroleum Company Data)

RATA calculations are based on 9 of 11 runs. * indicates the excluded runs.

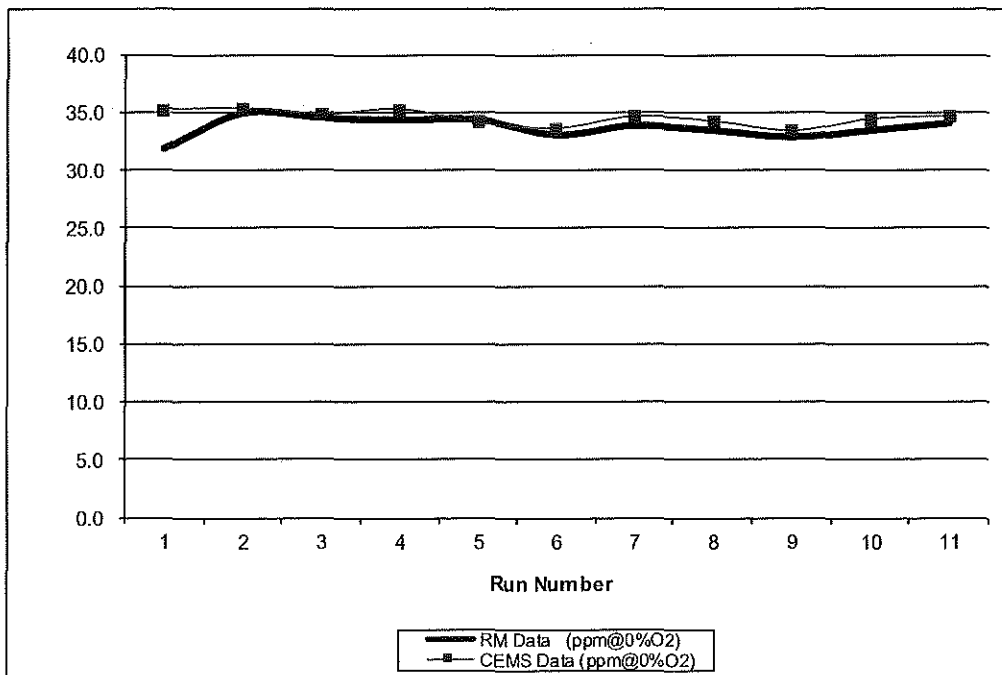

**Table 2-4:
CCR Interheater Stack – H₂SO₄ Emissions**

Run No.	1	2	3	Average
Date (2017)	Jun 29	Jun 29	Jun 29	
Start Time (approx.)	09:13	10:27	11:36	
Stop Time (approx.)	10:13	11:27	12:36	
Process Conditions				
P ₁ Fuel gas flow rate (Mscf/day)	2,817	2,819	2,826	2,821
P ₂ Feed rate (bpd)	21,004	20,998	21,008	21,003
F _d Oxygen-based F-factor (dscf/MMBtu)	8,276	8,276	8,276	8,276
Gas Conditions				
O ₂ Oxygen (dry volume %)	6.9	7.2	6.4	6.8
CO ₂ Carbon dioxide (dry volume %)	8.1	7.8	8.4	8.1
T _s Sample temperature (°F)	528	527	526	527
B _w Actual water vapor in gas (% by volume)	14.2	14.3	13.9	14.1
Sampling Data				
V _{mstd} Volume metered, standard (dscf)	26.44	25.96	26.36	26.25
Laboratory Data (Ion Chromatography)				
m _n Total H ₂ SO ₄ collected (mg)	0.6274	0.6418	0.5872	
Sulfuric Acid Vapor (H₂SO₄) Results				
C _{sd} H ₂ SO ₄ Concentration (lb/dscf)	5.23E-08	5.45E-08	4.91E-08	5.20E-08
C _{sd} H ₂ SO ₄ Concentration (ppm dv)	0.206	0.214	0.193	0.204
E _{Fd} H ₂ SO ₄ Rate - Fd-based (lb/MMBtu)	0.000646	0.000688	0.000586	0.000640

End of Section

3. DESCRIPTION OF INSTALLATION

Process Description

MPC's facility in Detroit, Michigan, produces refined petroleum products from crude oil. MPC must continue to demonstrate that select process units are in compliance with permitted emission limits.

The Continuous Catalytic Regeneration Platformer Unit (EG14-CCRPLATFORMER) is a catalytic reformer that rearranges the structure of low octane naphtha feed into higher-octane reformates. Hydrogen is produced as a product of the reaction and is used in other refinery processes. The CCR Interheater (EU14-CCRPLINTHTR) heats the intermediate reformate reactants prior to its re-entry into the multi-staged reactor system.

The unit is fired by refinery fuel gas. Emissions are vented to the atmosphere via the CCR Interheater Stack (SV14-H4A) where testing was performed.

Test Location

The sample point locations were determined by EPA Methods 1 and 7E specifications. Table 3-1 presents the sampling information for the test location described in this report. The figures shown on pages 10 and 11 represent the layout of the test location.

**Table 3-1:
Sampling Point Information**

Source Constituent	Method	Run No.	Ports	Points per Port	Minutes per Point	Total Minutes	Figure
<i>CCR Interheater</i>							
FPM/CPM (PM ₁₀)	EPA M5/202	1-3	2	12	5	120	3-1
H ₂ SO ₄	Draft ASTM CCM	1-3	1	1	60	60	N/A ¹
O ₂ / NO _x (RATA)	EPA M3A/7E	1-11	1	3	7	21	3-2

¹ Sampling occurred at a single point near the center of duct.

**Figure 3-1:
 FPM & PM₁₀ Sample Point Layout (EPA Method 1)**

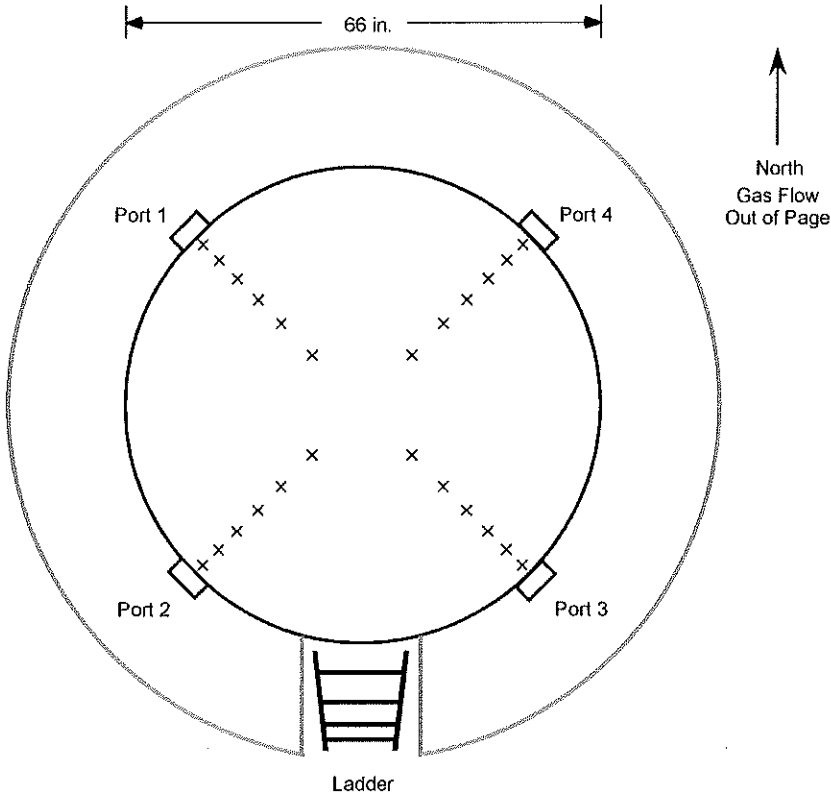

Samplin Point	% of Stack Diameter	Port to Point Distance (inches)
1	97.9	64.6
2	93.3	61.6
3	88.2	58.2
4	82.3	54.3
5	75.0	49.5
6	64.4	42.5
7	35.6	23.5
8	25.0	16.5
9	17.7	11.7
10	11.8	7.8
11	6.7	4.4
12	2.1	1.4

Duct diameters upstream from flow disturbance (A): 13.1
 Duct diameters downstream from flow disturbance (B): 3.6

Limit: 0.5
 Limit: 2.0

**Figure 3-2:
 O₂ & NO_x Sample Point Layout (EPA Method 7E)**

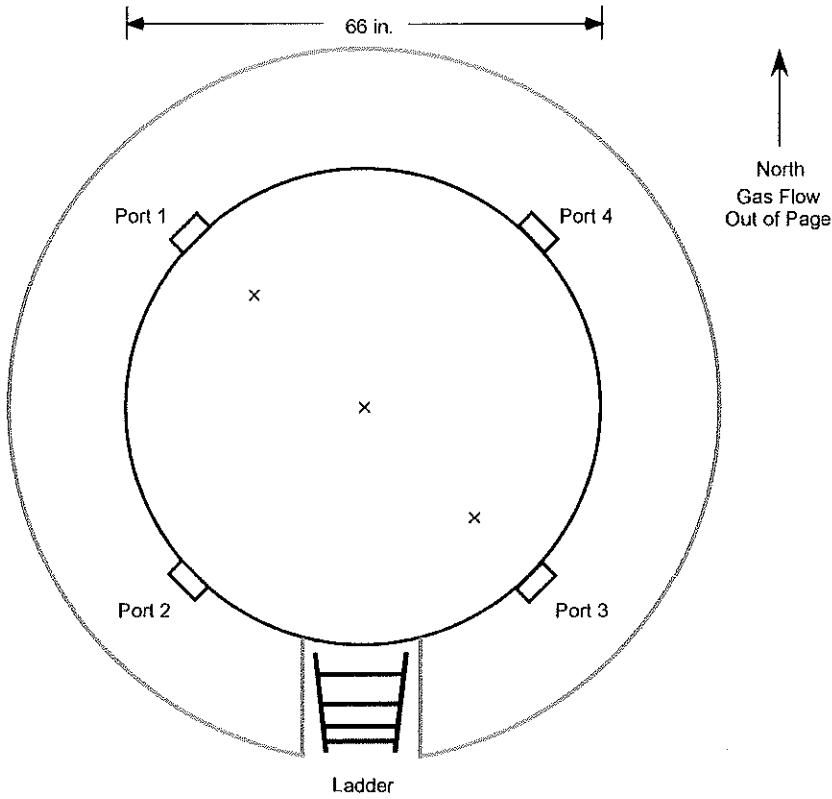

Sampling Point	% of Stack Diameter	Port to Point Distance (inches)
1	83.3	55.0
2	50.0	33.0
3	16.7	11.0

Duct diameters upstream from flow disturbance (A): 13.1
 Duct diameters downstream from flow disturbance (B): 3.6

Limit: 0.5
 Limit: 2.0

End of Section

4. METHODOLOGY

Procedures and Regulations

The test program sampling measurements followed procedures and regulations outlined by the U.S. Environmental Protection Agency (USEPA) and the MDEQ. These methods appear in detail in Title 40 of the CFR and at <https://www.epa.gov/emc>. Appendix A includes diagrams of the sampling apparatus, as well as specifications for sampling, recovery and analytical procedures.

CleanAir follows specific QA/QC procedures outlined in the individual methods and in USEPA "Quality Assurance Handbook for Air Pollution Measurement Systems: Volume III Stationary Source-Specific Methods," EPA/600/R-94/038C. Appendix D contains additional QA/QC measures, as outlined in CleanAir's internal Quality Manual.

Title 40 CFR Part 60, Appendix A

Method 1	"Sample and Velocity Traverses for Stationary Sources"
Method 2	"Determination of Stack Gas Velocity and Volumetric Flow Rate (Type S Pitot Tube)"
Method 3	"Gas Analysis for the Determination of Dry Molecular Weight"
Method 3A	"Determination of Oxygen and Carbon Dioxide Concentrations in Emissions from Stationary Sources (Instrumental Analyzer Procedure)"
Method 3B	"Gas Analysis for the Determination of Emission Rate Correction Factor or Excess Air"
Method 4	"Determination of Moisture Content in Stack Gases"
Method 5	"Determination of Particulate Matter Emissions from Stationary Sources"
Method 7E	"Determination of Nitrogen Oxide Emissions from Stationary Sources (Instrumental Analyzer Procedure)"
Method 19	"Determination of Sulfur Dioxide Removal Efficiency and Particulate Matter, Sulfur Dioxide and Nitrogen Oxide Emission Rates"

Title 40 CFR Part 60, Appendix B Performance Specifications

PS2	"Specifications and Test Procedures for SO ₂ and NO _x Continuous Emission Monitoring Systems in Stationary Sources"
PS3	"Specifications and Test Procedures for O ₂ and CO ₂ Continuous Emission Monitoring Systems in Stationary Sources"

Title 40 CFR Part 51, Appendix M

Method 202	"Dry Impinger Method for Determining Condensable Particulate Emissions from Stationary Sources"
------------	---

CTM-013 (Mod.)/Draft ASTM Controlled Condensation Method (Draft ASTM CCM)

"Determination of Sulfur Oxides Including Sulfur Dioxide, Sulfur Trioxide and Sulfuric Acid Vapor and Mist from Stationary Sources Using a Controlled Condensation Sampling Apparatus"

Methodology Discussion

FPM and PM₁₀ Testing – USEPA Method 5/202

The front-half (EPA Method 5 portion) of the sampling train consisted of a glass nozzle, glass liner and filter holder heated to 248°F ± 25°F and a quartz fiber filter. Flue gas samples were extracted isokinetically per Method 5 requirements.

The back-half (EPA Method 202 portion) of the sampling train is designed to mimic ambient conditions and collect only the particles that would truly form CPM in the atmosphere by minimizing the sulfur dioxide (SO₂) and NO_x interferences observed with earlier versions of the method, in which flue gas was bubbled through cold water, and SO₂ and NO_x were absorbed and partially oxidized before they could be purged out with nitrogen (N₂).

Flue gas exiting the front-half heated filter passed through a coiled condenser and dry impinger system jacketed by water continually circulated at ambient temperature. Moisture was removed from the flue gas without bubbling through the condensed water. Flue gas then passed through a tetrafluoroethane (TFE) membrane filter at ambient temperature. The temperature of the flue gas at the exit of the filter was directly measured with an in-line thermocouple and maintained in the temperature range of 65°F to 85°F.

After exiting the ambient filter, the flue gas passed through two (2) additional impingers surrounded by ice in a “cold” section of the impinger bucket. The moisture collected in these impingers was not analyzed for CPM and was only collected to determine the flue gas moisture and thoroughly dry the gas. The sample gas then flowed into a calibrated dry gas meter where the collected sample gas volume was determined.

The front-half portion of the sample train (nozzle, probe and heated filter) was recovered per Method 5 requirements, using acetone as the recovery solvent. The back-half of the sample train (heated filter outlet, condenser, dry impingers and TFE membrane filter) was recovered per Method 202 requirements. The impinger train was purged with N₂ at a rate of 14 liters per minute (lpm) for one (1) hour following each test run and prior to recovery.

A field train blank was assembled, purged and recovered as if it were an actual test sample; analysis of the field train blank was used to blank-correct the test run results. Reagent blanks were also collected to quantify background contamination. All samples and blanks were returned to CleanAir Analytical Services for gravimetric analysis. Method 202 samples were maintained at a temperature < 85°F during transport to the laboratory.

O₂, CO₂ & NO_x Testing – USEPA Methods 3A and 7E

Reference method O₂ and carbon dioxide (CO₂) emissions were determined using a paramagnetic/NDIR analyzer per EPA Method 3A. Reference method NO_x emissions were determined using a chemiluminescent analyzer per EPA Method 7E.

Sample gas was extracted at a constant rate, conditioned to remove moisture and delivered to an analyzer bank which measured concentration on a dry basis (units of %dv or ppm_{dv}).

Calibration error checks were performed by introducing zero N₂, high range and mid-range calibration gases to the inlet of each analyzer during calibration error checks. Bias checks were performed before and after each sampling run by introducing calibration gas to the inlet of the sampling system's heated filter. Per Methods 3A and 7E, the average results for each run was drift-corrected.

H₂SO₄ Testing – Draft ASTM CCM

A gas sample was extracted from the source at a constant flow rate from the source using a quartz-lined probe maintained at a temperature of 650°F ± 25°F (depending on the required probe length) and a quartz fiber filter maintained at the same temperature as the probe to remove particulate matter.

The sample then passed through a glass coil condenser for collection of sulfuric acid vapor and/or mist. A second quartz fiber filter (referred to as the sulfuric acid mist (SAM) filter) was located at the condenser outlet for the collection of residual SAM not collected by the condenser. The condenser temperature was regulated by a water jacket and the SAM filter was regulated by a closed oven. Both the water jacket and SAM filter oven were maintained at 140°F ± 9°F.

After exiting the SAM filter, the sample gas continued through a series of four (4) glass knock-out jars; two (2) containing water, one (1) empty and one (1) containing silica gel for residual moisture removal. The exit temperature from the knock-out jar set was maintained below 68°F. The sample gas then flowed into a dry gas meter, where the collected sample gas volume was determined by means of a calibrated, dry gas meter or an orifice-based flow meter.

The H₂SO₄-collecting portion of the sample train (condenser and SAM filter) was recovered into a single fraction using deionized (DI) H₂O as the recovery/extraction solvent; any H₂SO₄ disassociates into sulfate ion (SO₄²⁻) and is stabilized in the H₂O matrix until analysis.

Samples and blanks were returned to CleanAir Analytical Services for ion chromatography (IC) analysis.

End of Section