

RECEIVED

OCT 19 2023

QUALITY DIVISION



**erthwrks**

AIR EMISSIONS TESTING FOR INDUSTRY

*Relative Accuracy Test Audit*

for

**Marathon Petroleum Company LP**

at the

**Marathon Detroit Refinery in Detroit, MI**

on the

**East Plant SRU (CX-2 SRU)**

**Unit: EU42-SULRECOV-S1**

**Permit No. MI-ROP-A9831-2012c**

Prepared for:



**Marathon  
Petroleum Company LP**

**Test Date: September 12, 2023**

**Erthwrks Project No. 9284.1.C3**



## Endorsement Page

This report was developed in accordance with the requirements designated in the applicable regulatory permit(s) and/or regulatory rules. To the best of my knowledge the techniques, instrumentation, and calculations presented in this report will serve to accurately and efficiently detail the results of the test campaign requirements.

### Erthwrks, Inc.

Name: Jarrod Hoskinson

Title: Senior Project Manager

Signature: 

This report has been reviewed for accuracy and completeness. The actions presented in this report are, to the best of my knowledge, an accurate representation of the results and findings of the test campaign. Erthwrks, Inc. operates in conformance with the requirements on ASTM D7036-04 Standard Practice for Competence of Air Emission Testing Bodies and is accredited as such by the Stack Testing Accreditation Council (STAC) and the American Association for Laboratory Accreditation (A2LA).

### Erthwrks, Inc.

Name: John Wood

Title: Technical Director

Signature: 

# Table of Contents

1.0	INTRODUCTION .....	4
1.1	Identification, location and dates of tests .....	4
1.2	Purpose of Testing.....	4
1.3	Description of Source.....	4
1.4	Contact Information .....	5
2.0	SUMMARY OF RESULTS .....	6
3.0	SOURCE DESCRIPTION.....	6
3.1	Description of the process .....	6
3.2	Applicable permit and source designation .....	6
3.3	Type and quantity of materials processed during tests .....	6
4.0	SAMPLING AND ANALYTICAL PROCEDURES.....	7
4.1	Gaseous Sampling – SO <sub>2</sub> and O <sub>2</sub> .....	7
4.2	RATA Procedures .....	8
4.3	Discussion of sampling procedure or operational variances .....	9

## ATTACHMENTS

- A. Detailed Results of Emissions Test
- B. Quality Control Documentation
- C. Example Calculations
- D. Raw Datalog Records
- E. Calibrations and Certifications
- F. CEMS Logs and Operational Data

## 1.0 INTRODUCTION

### 1.1 Identification, location and dates of tests

Erthwrks, Inc. was contracted to conduct emissions testing on the East Plant SRU in operation at the Marathon Detroit Refinery, located in Detroit Michigan. The testing program was conducted on September 12, 2023.

### 1.2 Purpose of Testing

The exhaust from East Plant SRU was sampled and analyzed to determine the relative accuracy of the associated sulfur dioxide (SO<sub>2</sub>) and oxygen (O<sub>2</sub>) continuous emissions monitoring system (CEMS) in accordance with the requirements in the Marathon Permit No. MI-ROP-A9831-2012c and the Title 40 CFR Part 60, Appendix F.

### 1.3 Description of Source

Marathon Petroleum Company LP operates the East Plant SRU (EU42-SULRECOV-S1) under EGLE Renewable Operating Permit No. MI-ROP-A9831-2012c and is required to conduct an annual RATA to demonstrate the relative accuracy of the CEMS associated with this unit.

**Table 1.1—Marathon East Plant SRU CEMS Details**

East Plant SRU CEMS	Manufacturer	Model No.	S/N	Install Date
SO <sub>2</sub>	ABB	Limas 11	3.360778.8	2009
O <sub>2</sub>	ABB	Magnos 206	3.360981.8	2009

## 1.4 Contact Information

### **Marathon Petroleum Company LP**

Chase Every  
Environmental Engineer  
Michigan Refining Division  
313-551-6961 office  
248-302-0285 cell  
crevery@marathonpetroleum.com

### **Erthwrks, Inc.**

John Wood  
Technical Director  
P.O. Box 150549  
Austin, TX 78745  
512-585-1685 office  
888-573-9994 fax  
jwood@erthwrks.com

### **Erthwrks, Inc.**

Jarrold Hoskinson  
Senior Project Manager  
P.O. Box 150549  
Austin, TX 78745  
512-994-7487 office  
888-573-9994 fax  
jhoskinson@erthwrks.com

### **Erthwrks, Inc.**

Jason Dunn  
QC Specialist  
P.O. Box 150549  
Austin, TX 78745  
614-565-9177 office  
888-573-9994 fax  
jdunn@erthwrks.com

### **Facility Location:**

Marathon Petroleum Company LP  
Detroit Refinery  
1300 South Fort Street  
Detroit, MI 48217



## 2.0 SUMMARY OF RESULTS

**Table 2.1— Marathon NP SRU (EU42-SULRECOV-S1) CEMS RATA Results**

Pollutant Measured	Performance Specification	Relative Accuracy	Applicable Limit	Pass/Fail
SO <sub>2</sub> (ppmvd @ 0% O <sub>2</sub> )	Performance Spec. 2	5.7% <i>RA<sub>AS</sub></i>	10%	Pass
O <sub>2</sub> (%vd)	Performance Spec. 3	0.15% <i>RA<sub>MD</sub></i>	1%	Pass

## 3.0 SOURCE DESCRIPTION

### 3.1 Description of the process

Marathon Petroleum Company LP produces refined petroleum products from crude oil and is required to demonstrate that select process emission sources are operating in compliance with permitted emissions limits.

The East Plant Incinerator, or Sulfur Recovery Unit, removes H<sub>2</sub>S from the acid gas and converts it into elemental sulfur using the Claus Process (Trains A, B, and C), the SCOT Tail Gas Treating Unit process (Train No. 1 and No. 2), and associated amine treating equipment. Tail gas is routed to a thermal oxidizer, or incinerator, which oxidizes the remaining H<sub>2</sub>S in the tail gas to SO<sub>2</sub> before exhausting to the atmosphere via the SRU Incinerator Stack (SV43-H2). The emission group also consists of process vessels, heaters, tanks, containers, compressors, seals, process valves, flanges, connectors, etc.

### 3.2 Applicable permit and source designation

Marathon Petroleum Company LP operates the East Plant SRU (EU42-SULRECOV-S1) under EGLE Renewable Operating Permit No. MI-ROP-A9831-2012c and is required to conduct an annual RATA to demonstrate the relative accuracy of the CEMS associated with this unit.

### 3.3 Type and quantity of materials processed during tests

During the emission testing on September 12, 2023, at the Marathon Petroleum Company LP Refinery, the East Plant SRU was tested while operating at load conditions representative of normal conditions. The load conditions during the testing were documented by Marathon Detroit Refinery and provided in Appendix F.

## 4.0 SAMPLING AND ANALYTICAL PROCEDURES

### 4.1 Gaseous Sampling – SO<sub>2</sub> and O<sub>2</sub>

For the gaseous sampling, Erthwrks utilized a stainless-steel probe, of sufficient length to reach all sampling points, inserted into a sampling port that is located on the stack in accordance with EPA Method 1. The sample is extracted through the probe, a heated Teflon sampling line, to a heating filter. The sample then enters a minimum contact sample conditioner that cools and removes moisture from the gas matrix prior to entering the Erthwrks sampling manifold.

Erthwrks followed all quality assurance and quality control procedures as defined in US EPA 40 CFR 60 Appendix A. The Calibration Error (CE) Test was conducted as specified in EPA Method 7E §8.2.3. In accordance with this requirement, a three-point analyzer calibration error test was conducted prior to sampling. The CE test was conducted by introducing the low, mid, and high-level calibration gasses (as defined in EPA Method 7E §3.3.1-3) sequentially and the response was recorded. The results of the CE test are acceptable if the calculated calibration error is within  $\pm 2.0\%$  of calibration span (or  $\leq 0.5$  ppmv).

The Initial System Bias and System Calibration Error Check was conducted in accordance with EPA Method 7E §8.2.5. The upscale calibration gas was introduced at the probe upstream of all sample system components and the response recorded. The procedure was repeated with the low-level gas and the response recorded. During this activity, the sample system response time was also recorded. This specification is acceptable if the calculated values of the system calibration error check are within  $\pm 5.0\%$  of the calibration span value (or  $\leq 0.5$  ppmv).

After each test run, the sample system bias check is conducted to validate the run data. The low-level and upscale drift are calculated using Equation 7E-4. The run data is valid if the calculated drift is within  $\pm 3.0\%$  of the calibration span value (or  $\leq 0.5$  ppmv).

After each test run, the corrected effluent gas concentration was calculated as specified in EPA Method 7E §12.6. The arithmetic average of all valid concentration values are adjusted for bias using equation 7E-5B.

The figure below details the Erthwrks gaseous sampling system:

RECEIVED  
OCT 19 2023  
AIR QUALITY DIVISION



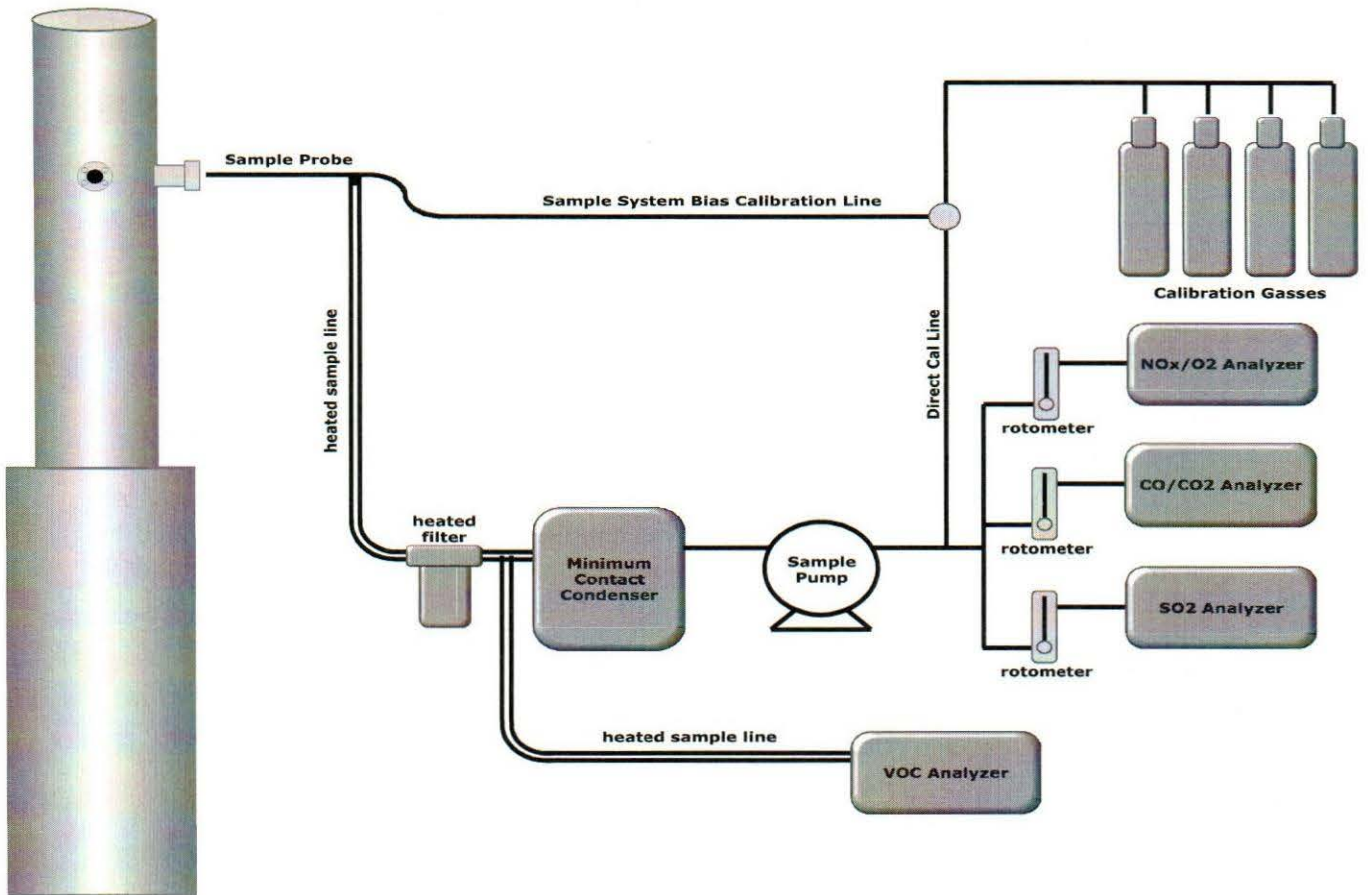

Figure 1: Example Erthwrks Gaseous Sampling System Diagram

## 4.2 RATA Procedures

The RATA testing was conducted following the sampling and measurement procedures found in the **EPA Part 60, Appendix B, Performance Specifications** which requires that EPA Reference Methods, from EPA Part 60, Appendix A, be utilized to conduct independent stack emissions measurements for comparison with installed CEMS readings. The following performance specifications will be used during this testing program.

- EPA Performance Specification 2 for SO<sub>2</sub> relative accuracy
- EPA Performance Specification 3 for O<sub>2</sub> relative accuracy

As required by these methods, the use EPA Protocol 1 gases are mandatory and were used for this portion of the project.



The RATA test is a direct comparison of the CEMS monitoring data with that data collected from an independently operated EPA Reference Method tests for each pollutant, following all the quality assurance and quality control procedures as required in the reference method. The following EPA reference methods were utilized to complete this testing program:

- EPA Method 3A for the determination of O<sub>2</sub> concentration
- EPA Method 6C for the determination of SO<sub>2</sub> concentration

For this testing program, Erthwrks utilized a calibration gas dilution system, operated in accordance with EPA Method 205, for the generation of the calibration gases used to calibrate the reference method analyzers. This gas dilution system is calibration annual in accordance with section 2.1.1 of this method. This documentation is located in Attachment E. In addition, the gas diluter accuracy was verified on the day of the test in accordance with the Field Evaluation procedure defined in Section 3.2 of the method. This activity is documented in Attachment B and the raw data logs are located in Attachment D.

The reference method sampling locations are defined in the Erthwrks QA/QC worksheet located in Attachment B. Three sampling points were used in accordance with the EPA Performance Specification 2, §8.1.3.2, located at 16.7, 50.0 and 83.3 percent of the stack inner diameter from the port location. Erthwrks sampled at each traverse point individually for 7-minutes per point for each 21-minute test run.

A minimum of nine (9) RATA test runs were conducted at each exhaust stack for a minimum duration of twenty-one (21) minutes for each run. A 3-point traverse located at 16.7%, 50.0%, and 83.3% of the way across the stack (or 0.4, 1.2, and 2.0 meters from the stack wall) was conducted during each RATA test run (7 minutes per point). The results of the reference method tests were compared to CEMS measurement data from the same time periods to determine the relative accuracy of the CEMS.

For SO<sub>2</sub>, the results of the RATA test are considered acceptable if the calculated relative accuracy does not exceed 20.0% as calculated by Equation 2-6 in Performance Specification 2. Alternatively, for affected units where the average of the reference method measurements is less than 50 percent of the emission standard (emission limit), the relative accuracy must not exceed 10% when the applicable emission standard is used in the denominator of Eq. 2-6.

For O<sub>2</sub>, the results of the RATA test are considered acceptable if the calculated relative accuracy does not exceed 20.0% as calculated by Equation 3.1 in Performance Specification 3. The results are also acceptable if the result of Equation 3-2 is less than or equal to 1.0 percent.

### **4.3 Discussion of sampling procedure or operational variances**

Erthwrks, Inc. conducted the emissions testing with no sampling or procedural variances.

**Attachment A**  
**Detailed Results of Emission Test**

## Erthwrks Relative Accuracy Test Audit--O<sub>2</sub> RATA Performance Specification 3

East Plant SRUO<sub>2</sub> CEMS RATA

Test Run	Run 1	Run 2	Run 3	Run 4	Run 5	Run 6	Run 7	Run 8	Run 9
Date	9/12/2023	9/12/2023	9/12/2023	9/12/2023	9/12/2023	9/12/2023	9/12/2023	9/12/2023	9/12/2023
Start Time	14:54	15:15	15:36	16:04	16:25	16:46	17:18	17:39	18:00
End Time	15:15	15:36	15:57	16:25	16:46	17:07	17:39	18:00	18:21
RM O <sub>2</sub> Result (%vd)	4.99	4.94	4.95	5.01	5.00	5.01	4.97	4.96	5.01
CEMS O <sub>2</sub> Data (%vd)	5.14	5.10	5.11	5.15	5.15	5.18	5.11	5.11	5.14
Difference	-0.15	-0.16	-0.16	-0.14	-0.15	-0.17	-0.14	-0.15	-0.13
Accept or Reject	Accept	Accept	Accept	Accept	Accept	Accept	Accept	Accept	Accept

Mean of the Difference ( $d_{avg}$ )

Standard Deviation ( $S_d$ )

Confidence Coefficient (CC)

**Relative Accuracy via RM,  $RA_{RM-CEMS}^*$**

-0.15
0.01
0.01
<b>0.15%</b>

← Pass

\* $RA_{RM-CEMS}$  (Reference Method - CEMS) Absolute difference must be less than 1.0%

## Erthwrks Relative Accuracy Test Audit--SO<sub>2</sub> RATA Performance Specification 2

East Plant SRU								SO <sub>2</sub> CEMS RATA - O <sub>2</sub> Corrected			
Test Run	Run 1	Run 2	Run 3	Run 4	Run 5	Run 6	Run 7	Run 8	Run 9	Run 10	
Date	9/12/2023	9/12/2023	9/12/2023	9/12/2023	9/12/2023	9/12/2023	9/12/2023	9/12/2023	9/12/2023	9/12/2023	
Start Time	14:54	15:15	15:36	16:04	16:25	16:46	17:18	17:39	18:00	18:31	
End Time	15:15	15:36	15:57	16:25	16:46	17:07	17:39	18:00	18:21	18:52	
RM SO <sub>2</sub> Results (ppmvd)	70.66	70.95	71.30	73.19	69.57	70.45	66.85	69.21	68.98	68.21	
RM O <sub>2</sub> Results (%vd)	4.99	4.94	4.95	5.01	5.00	5.01	4.97	4.96	5.01	5.20	
RM SO <sub>2</sub> Result (ppmvd @ 0% O <sub>2</sub> )	<b>92.82</b>	<b>92.91</b>	<b>93.43</b>	<b>96.27</b>	<b>91.45</b>	<b>92.66</b>	<b>87.71</b>	<b>90.75</b>	<b>90.73</b>	<b>90.80</b>	
CEMS SO <sub>2</sub> Result (ppmvd @ 0% O <sub>2</sub> )	<b>103.74</b>	<b>104.47</b>	<b>106.22</b>	<b>109.19</b>	<b>107.48</b>	<b>103.80</b>	<b>101.92</b>	<b>103.72</b>	<b>104.98</b>	<b>0.00</b>	
Difference	-10.92	-11.56	-12.79	-12.92	-16.04	-11.14	-14.22	-12.97	-14.25	90.80	
Accept or Reject	Accept	Accept	Accept	Accept	Accept	Accept	Accept	Accept	Accept	Reject	

Applicable Standard (ppmvd @ 0% O<sub>2</sub>)

Mean of the Difference (d<sub>avg</sub>)

Standard Deviation (S<sub>d</sub>)

Confidence Coefficient (CC)

Relative Accuracy via AS, RA<sub>AS</sub><sup>†</sup>

\*RA<sub>RM</sub> (Reference Method) must be less than 20%

<sup>†</sup>RA<sub>AS</sub> (Applicable Standard) must be less than 10%

250
-12.98
1.665
1.28
<b>5.70%</b> ← Pass

**Attachment B**  
**Quality Control Documentation**

## Erthwrks Method 1 Traverse Point Location Worksheet

**Client:** Marathon Petroleum Company  
**Project #:** 9284.1.C3  
**Facility:** Detroit Refinery  
**Unit ID:** East Plant SRU  
**Technician:** M. Oleszko

**Stack ID Measurements**

Stack ID + Port (inches):	107
Port Extension (inches):	23
Stack Diameter (inches):	84

**Port Location Measurements**

Distance Upstream (A) (inches):	70
Distance Downstream (B) (inches):	200
Stack Diameters Upstream (A):	0.8
Stack Diameters Downstream (B):	2.4

Total Traverse Points to be used:	3
Traverse Points per Diameter:	3

Traverse Point Locations <sup>(1)(2)</sup>	
Point 1:	14.03"
Point 2:	42.00"
Point 3:	69.97"

**Stack Cross Section View**

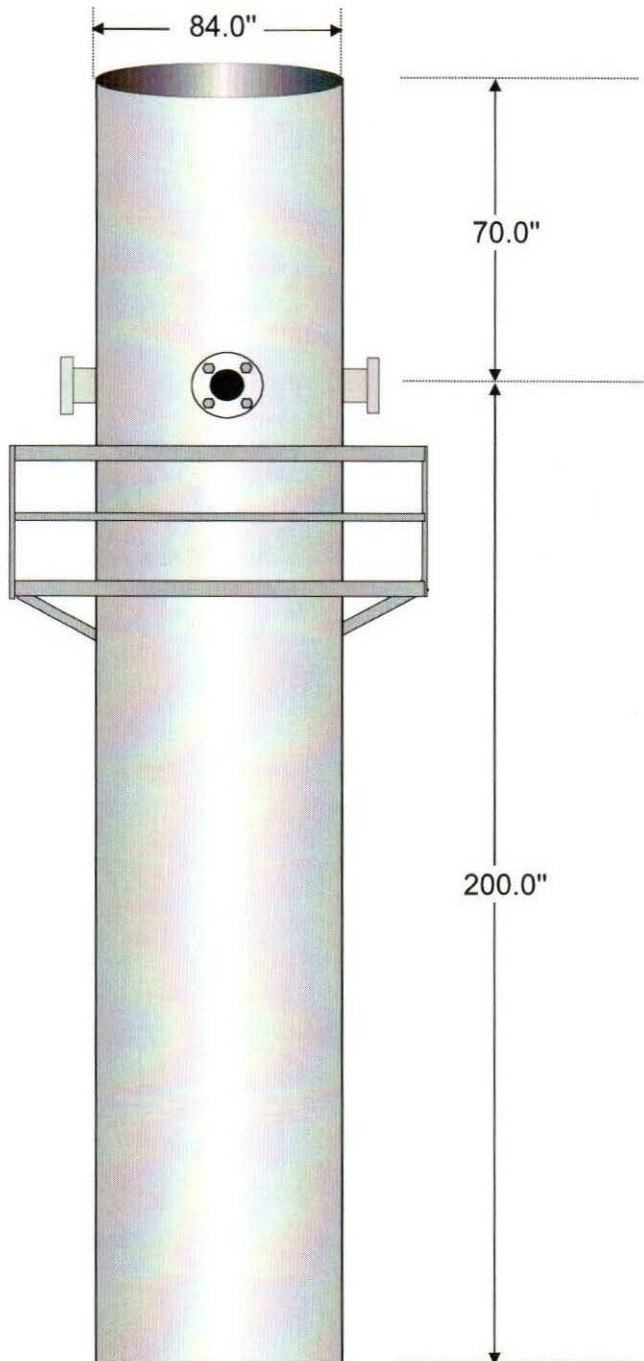
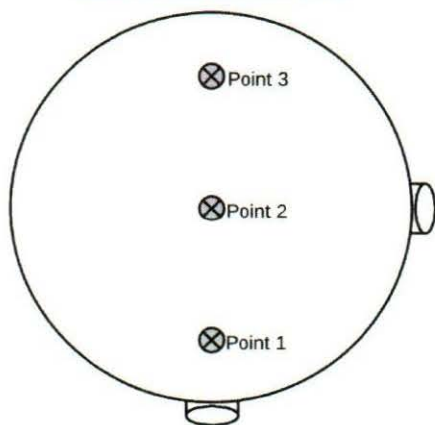

<sup>(1)</sup>For stack diameter >4.0" and <2.4 meters, stratification is measured at 16.7%, 50.0%, and 83.3" of stack diameter (M7E, §8.1.2).

<sup>(2)</sup>For stack diameter >2.4 meters, stratification is measured at 0.4, 1.2, and 2.0 meters from stack wall (M7E, §8.1.2).