



Consumers Energy

Count on Us[®]

PM and HCl 40 CFR 63, Subpart UUUUU Test Report

EUBOILER2

Consumers Energy Company
J.H. Campbell Plant
17000 Croswell Street
West Olive, Michigan 49460
SRN: B2835
FRS: 110000411108

August 1, 2019

Test Dates: June 10 and 12, 2019

Test performed by the Consumers Energy Company
Regulatory Compliance Testing Section
Air Emissions Testing Body
Laboratory Services Department
Work Order No. 31805898
Version No.: 0

TABLE OF CONTENTS

EXECUTIVE SUMMARY	IV
1.0 INTRODUCTION	1
1.1 IDENTIFICATION, LOCATION, AND DATES OF TESTS	1
1.2 PURPOSE OF TESTING	1
1.3 BRIEF DESCRIPTION OF SOURCE	2
1.4 CONTACT INFORMATION	2
2.0 SUMMARY OF RESULTS	3
2.1 OPERATING DATA	3
2.2 APPLICABLE PERMIT INFORMATION	3
2.3 RESULTS.....	3
3.0 SOURCE DESCRIPTION	4
3.1 PROCESS	4
3.2 PROCESS FLOW	4
3.3 MATERIALS PROCESSED	5
3.4 RATED CAPACITY	5
3.5 PROCESS INSTRUMENTATION	5
4.0 SAMPLING AND ANALYTICAL PROCEDURES	5
4.1 DESCRIPTION OF SAMPLING TRAIN AND FIELD PROCEDURES.....	6
4.1.1 SAMPLE LOCATION AND TRAVERSE POINTS (USEPA METHOD 1).....	6
4.1.2 VELOCITY AND TEMPERATURE (USEPA METHOD 2).....	7
4.1.3 MOLECULAR WEIGHT (USEPA ALT-123)	8
4.1.4 MOISTURE CONTENT (USEPA METHOD 4)	9
4.1.5 PARTICULATE MATTER AND HYDROGEN CHLORIDE (USEPA METHODS 5 AND 26A)	9
4.1.6 EMISSION RATES (USEPA METHOD 19)	13
5.0 TEST RESULTS AND DISCUSSION	14
5.1 TABULATION OF RESULTS	14
5.2 SIGNIFICANCE OF RESULTS	15
5.3 VARIATIONS FROM SAMPLING OR OPERATING CONDITIONS	15
5.4 PROCESS OR CONTROL EQUIPMENT UPSET CONDITIONS.....	15
5.5 AIR POLLUTION CONTROL DEVICE MAINTENANCE	15
5.6 RE-TEST DISCUSSION.....	15
5.7 RESULTS OF AUDIT SAMPLES	15
5.7.1 PERFORMANCE AUDIT SAMPLE	15
5.7.2 REFERENCE METHOD AUDITS	16
5.8 CALIBRATION SHEETS.....	17
5.9 SAMPLE CALCULATIONS	17
5.10 FIELD DATA SHEETS.....	17
5.11 LABORATORY QUALITY ASSURANCE / QUALITY CONTROL PROCEDURES	17
5.11.1 QA/QC BLANKS.....	17

FIGURES

FIGURE 3-1. UNIT 2 DATA FLOW DIAGRAM.....	4
FIGURE 4-1. UNIT 2 DUCT CROSS SECTION AND TEST PORT/TRVERSE POINT DETAIL.....	7
FIGURE 4-2. METHOD 2 SAMPLE APPARATUS.....	8
FIGURE 4-3. USEPA METHOD 3A SAMPLING SYSTEM	9
FIGURE 4-4. USEPA METHODS 5 AND 26A SAMPLING APPARATUS.....	11
FIGURE 4-5. USEPA METHODS 5 AND 26A SAMPLE RECOVERY SCHEME	12
FIGURE 4-6. USEPA METHODS 5 AND 26A ANALYTICAL SCHEME.....	13
FIGURE 4-7. USEPA METHOD 19 EQUATION 19-6	13

TABLES

TABLE E-1 SUMMARY OF JHC EUBOILER2 TEST RESULTS	IV
TABLE 1-1 APPLICABLE MATS EMISSION LIMITS	1
TABLE 1-2 CONTACT INFORMATION.....	2
TABLE 2-1 SUMMARY OF TEST RESULTS	3
TABLE 4-1 TEST METHODS	6
TABLE 4-2 TEST MATRIX	6
TABLE 4-3 USEPA METHODS 5 AND 26A IMPINGER CONFIGURATION.....	10
TABLE 5-1 MATS LEE PM AND HCL TEST EVENT CHRONOLOGY, JHC UNIT 2.....	14
TABLE 5-2 QA/QC PROCEDURES	16
TABLE 5-3 QA/QC BLANKS	18

APPENDICES

Appendix Table 1	Particulate Matter and Hydrogen Chloride Results
Appendix A	Sample Calculations
Appendix B	Field Data Sheets
Appendix C	Laboratory Data Sheets
Appendix D	Operating Data
Appendix E	Supporting Documentation

EXECUTIVE SUMMARY

Consumers Energy Regulatory Compliance Testing Section (RCTS) conducted filterable particulate matter (PM) and hydrogen chloride (HCl) testing at the exhaust of coal-fired boiler EUBOILER2 (Unit 2), an electric utility steam generating unit (EGU) which generates steam to turn a turbine and generate electricity at the J.H. Campbell Generating Station in West Olive, Michigan. The test program was performed on June 10 and 12, 2019 to satisfy the 2019 second quarter PM and HCl performance testing requirements and evaluate compliance with 40 CFR 63, Subpart UUUUU, *National Emission Standards for Hazardous Air Pollutants: Coal- and Oil-Fired Electric Utility Steam Generating Units*, (aka Mercury and Air Toxics Rule [MATS]) as incorporated in the Michigan Department of Environmental Quality (MDEQ) Renewable Operating Permit (ROP) MI-ROP-B2835-2013b.

Triplicate 125-minute PM and HCl test runs were conducted following the procedures in United States Environmental Protection Agency (USEPA) Reference Methods (RM) 1, 2, 3A, 4, 5, 19, and 26A in 40 CFR 60, Appendix A. During testing, Unit 2 was operated while firing 100% western coal at an operating load representative of site specific normal operations as specified in 40 CFR §63.10007(2). There were no deviations from the approved stack test protocol or the USEPA Reference Methods therein. The Unit 2 PM and HCl results are summarized in the following table.

**Table E-1
Summary of JHC EUBOILER2 Test Results**

Parameter	Units	Run			Average	Emission Limit	
		1	2	3		MATS	MATS LEE ¹
PM	lb/mmBtu	0.0016	0.0018	0.0012	0.0015	0.030	0.015
HCl	lb/mmBtu	<0.00006	<0.00006	0.00005	<0.00006	0.0020	0.0010

¹ Applicable qualifying emission limit for low emitting EGU (LEE) status

The Unit 2 PM and HCl test results indicate the boiler emissions are in compliance with applicable MATS regulation limits and the low emitting EGU (LEE) qualification thresholds. The results of the testing indicate compliance with the MATS rule and ROP and demonstrates that EUBOILER2 operating at the J.H. Campbell Generating Station qualifies as a low-emitting EGU (LEE) for PM and HCl.

Based on the results of the particulate matter and hydrogen chloride performance testing for the past 12 continuous quarters (refer to Table 5-1), where each emission test is in compliance with the LEE criteria, stack tests will be completed once every 36 months to demonstrate continued LEE status in accordance with 40 CFR 63.10000(c)(1)(iii).

Detailed results are presented in Appendix Table 1. Sample calculations, field data sheets, and laboratory data are presented in Appendices A, B, and C. Boiler operating data and supporting documentation are provided in Appendices D and E.

1.0 INTRODUCTION

This report summarizes the results of compliance filterable particulate matter (PM) and hydrogen chloride (HCl) air emissions tests conducted June 10 and 12, 2019 on EUBOILER2 operating at the Consumers Energy J.H. Campbell Plant in West Olive, Michigan.

This document was prepared using the Michigan Department of Environmental Quality (MDEQ) *Format for Submittal of Source Emission Test Plans and Reports* published in March of 2018. Note that as of April 22, 2019, the MDEQ was re-organized and re-named the Michigan Department of Environment, Great Lakes, and Energy (EGLE). Please exercise due care if portions of this report are reproduced, as critical substantiating documentation and/or other information may be omitted or taken out of context.

1.1 IDENTIFICATION, LOCATION, AND DATES OF TESTS

Consumers Energy Regulatory Compliance Testing Section (RCTS) conducted PM and HCl tests at the dedicated exhaust of coal-fired boiler EUBOILER2 (Unit 2) operating at the J.H. Campbell Generating Station in West Olive, Michigan on June 10 and 12, 2019.

A test protocol was submitted to the MDEQ on September 23, 2016 and subsequently approved by Mr. Tom Gasloli, Environmental Quality Analyst, in his letter dated October 18, 2016. The approval letter reflects standing blanket approval of all quarterly MATS tests conducted at J.H. Campbell Units 1 and 2 as long as no modifications from the original protocol occur; however, updated and agency approved EGU diluent gas collection and analysis procedures in the March, 2018 USEPA publication ALT-123 may be implemented.

1.2 PURPOSE OF TESTING

The test program was performed to evaluate EUBOILER2 compliance with applicable PM and HCl limits and to demonstrate initial qualification as a low emitting electrical generating unit (LEE) as specified in 40 CFR 63, Subpart UUUUU, *National Emission Standards for Hazardous Air Pollutants: Coal- and Oil-Fired Electric Utility Steam Generating Units*, (aka Mercury and Air Toxics Rule [MATS]) as incorporated in the Michigan Department of Environmental Quality (MDEQ) Renewable Operating Permit (ROP) MI-ROP-B2835-2013b. The applicable MATS emission limits are presented in Table 1-1.

Table 1-1
Applicable MATS Emission Limits

Parameter	Emission Limit	Units	Applicable Requirement
PM	0.030	lb/mmBtu	Table 2 to Subpart UUUUU of Part 63— Emission Limits for Existing EGU's
HCl	0.0020		
lb/mmBtu		pound per million British thermal unit heat input	

Qualifying for MATS LEE status requires demonstrating the EGU emissions are less than or equal to 50 percent of the 0.030 lb/mmBtu PM and 0.0020 lb/mmBtu HCl applicable standards in Table 2 of the MATS rule on a quarterly basis over a three-year period (i.e., 12 quarterly tests).

This MATS test event represents the 12th consecutive quarterly Unit 2 PM and HCI LEE demonstration successfully meeting the LEE eligibility criteria of 63.10005(h).

1.3 BRIEF DESCRIPTION OF SOURCE

EUBOILER2 is a coal-fired EGU that operates as needed to provide electricity to the regional grid and Consumers Energy customers.

1.4 CONTACT INFORMATION

Table 1-2 presents the names, addresses, and telephone numbers of the contacts for information regarding the test and the test report, and names and affiliation of personnel involved in conducting the testing.

**Table 1-2
Contact Information**

Program Role	Contact	Address
State Regulatory Administrator	Ms. Karen Kajiya-Mills Technical Programs Unit Manager 517-335-4874 kajiya-millsk@michigan.gov	Michigan Department of Environment, Great Lakes, and Energy Technical Programs Unit 525 W. Allegan, Constitution Hall, 2nd Floor S Lansing, Michigan 48933
State Technical Programs Field Inspector	Mr. Tom Gasloli Technical Programs Unit Environmental Quality Analyst 517-284-6778 gaslolit@michigan.gov	Michigan Department of Environment, Great Lakes, and Energy Technical Programs Unit 525 W. Allegan, Constitution Hall, 2nd Floor S Lansing, Michigan 48933
State Regulatory Inspector	Ms. Kaitlyn DeVries Environmental Quality Analyst 616-558-0552 devriesk1@michigan.gov	Michigan Department of Environment, Great Lakes, and Energy Grand Rapids District Office 350 Ottawa Avenue NW; Unit 10 Grand Rapids, Michigan 49503
Responsible Official	Mr. Norman J. Kapala Exec. Director of Coal Generation 616-738-3200 norman.kapala@cmsenergy.com	Consumers Energy Company J.H. Campbell Power Plant 17000 Croswell Street West Olive, Michigan 49460
Corporate Air Quality Contact	Mr. James M. Walker Senior Engineer Lead 517-788-0428 james.walker@cmsenergy.com	Consumers Energy Company Environmental Services Department 1945 West Parnall Road; P22-121 Jackson, Michigan 49201
Test Facility	Mr. Joseph J. Firlit Sr. Engineering Tech Analyst Lead 616-738-3260 joseph.firlit@cmsenergy.com	Consumers Energy Company J.H. Campbell Power Plant 17000 Croswell Street West Olive, Michigan 49460
Test Facility	Mr. Michael T. Rabideau Senior Technician 616-738-3234 michael.rabideau@cmsenergy.com	Consumers Energy Company J.H. Campbell Power Plant 17000 Croswell Street West Olive, Michigan 49460
Test Team Representative	Mr. Gregg A. Koteskey, QSTI Engineering Technical Analyst 616-738-3712 gregg.koteskey@cmsenergy.com	Consumers Energy Company L&D Training Center 17010 Croswell Street West Olive, Michigan 49460
Laboratory	Mr. Gordon Cattell 517-788-2334 Sr. Laboratory Tech Analyst Lead gordon.cattell@cmsenergy.com	Consumers Energy Company Laboratory Services 135 W Trail Street Jackson, Michigan 49201

2.0 SUMMARY OF RESULTS

2.1 OPERATING DATA

The boiler fired 100% western coal during the performance test and operated at an average load of 289 gross megawatts (MWg), equating to 96.3% of the achievable capacity of approximately 300 MWg based upon the coal blend. See Section 3.4 for further detail. 40 CFR §63.10007(2) describes maximum normal operating load is generally between 90 and 110 percent of design capacity but should be representative of site specific normal operations during each test run.

Refer to Attachment D for detailed operating data. The CEMS data is recorded in Eastern Standard Time (EST). Note the time convention for the reference method (RM) testing and Dry Sorbent Injection (DSI) process feed rates were in Eastern Daylight Savings Time (EDT), so there is a one hour offset between the CEMS data (i.e., Load, % CO₂ (wet), % Opacity and SO₂ lb/mmBtu rate) and the remainder of the information.

2.2 APPLICABLE PERMIT INFORMATION

The J.H. Campbell generating station, State of Michigan Registration Number (SRN) B2835, operates in accordance with and ROP MI-ROP-B2835-2013b, which incorporates State and Federal air regulations, including applicable MATS Rule requirements. The permit identifies EUBOILER2 as an emission unit within the flexible group designation FGBOILER12. The facility is also associated with Federal Registry Service (FRS) ID: 110000411108.

Additionally, Consumers Energy operates Unit 2 in accordance with the requirements in Consent Decree (CD), Civil Action No.: 14-13580, entered between Consumers Energy, the United States Environmental Protection Agency (EPA), and the United States Department of Justice (DOJ) on November 4, 2014.

2.3 RESULTS

The Unit 2 results indicate the 3-run average PM and HCl emissions comply with applicable MATS regulation limits and the associated qualifying low emitting EGU (LEE) emission rate thresholds. Refer to Table 2-1 for a summary of the PM and HCl test results.

**Table 2-1
Summary of Test Results**

Parameter	Units	Run			Average	Emission Limit	
		1	2	3		MATS	MATS LEE ¹
PM	lb/mmBtu	0.0016	0.0018	0.0012	0.0015	0.030	0.015
HCl	lb/mmBtu	<0.00006	<0.00006	0.00005	<0.00006	0.0020	0.0010
¹ Applicable qualifying emission limit for low emitting EGU (LEE) status							

Detailed results are presented in Appendix Table 1. A discussion of the results is presented in Section 5.0. Sample calculations, field data sheets, and laboratory results are presented in Appendices A, B, and C. Boiler operating data and supporting information are provided in Appendices D and E.

3.0 SOURCE DESCRIPTION

EUBOILER2 is a coal-fired EGU that turns a turbine connected to an electricity producing generator.

3.1 PROCESS

Unit 2 is a wall-fired boiler, classified as an existing unit under MATS, which combusts pulverized subbituminous coal as the primary fuel and oil as an ignition/flame stabilization fuel. The unit is also permitted to burn eastern coal blends. Coal is fired in the furnace where the combustion heats water within boiler tubes producing steam. The steam turns a turbine that is connected to an electricity producing generator. The electricity is routed through the transmission and distribution system to consumers.

3.2 PROCESS FLOW

The flue gas generated through coal combustion is controlled by multiple pollution control devices. The unit is currently equipped with low nitrogen oxides (NO_x) burners (LNB), a selective catalytic reduction (SCR) system for NO_x control, a dry sorbent (lime) injection (DSI) system for control of sulfur dioxides (SO₂) and other acid gasses, an activated carbon injection (ACI) system for mercury (Hg) reduction, and a pulse jet fabric filter (PJFF) baghouse to control PM emissions. Post control flue gas exhausts to atmosphere through an approximately 400-foot high stack shared with EUBOILER1. CEMS and reference method measurements are conducted in a dedicated exhaust duct upstream of the common stack. Refer to Figure 3-1 for the Unit 2 Data Flow Diagram.

Figure 3-1. Unit 2 Data Flow Diagram

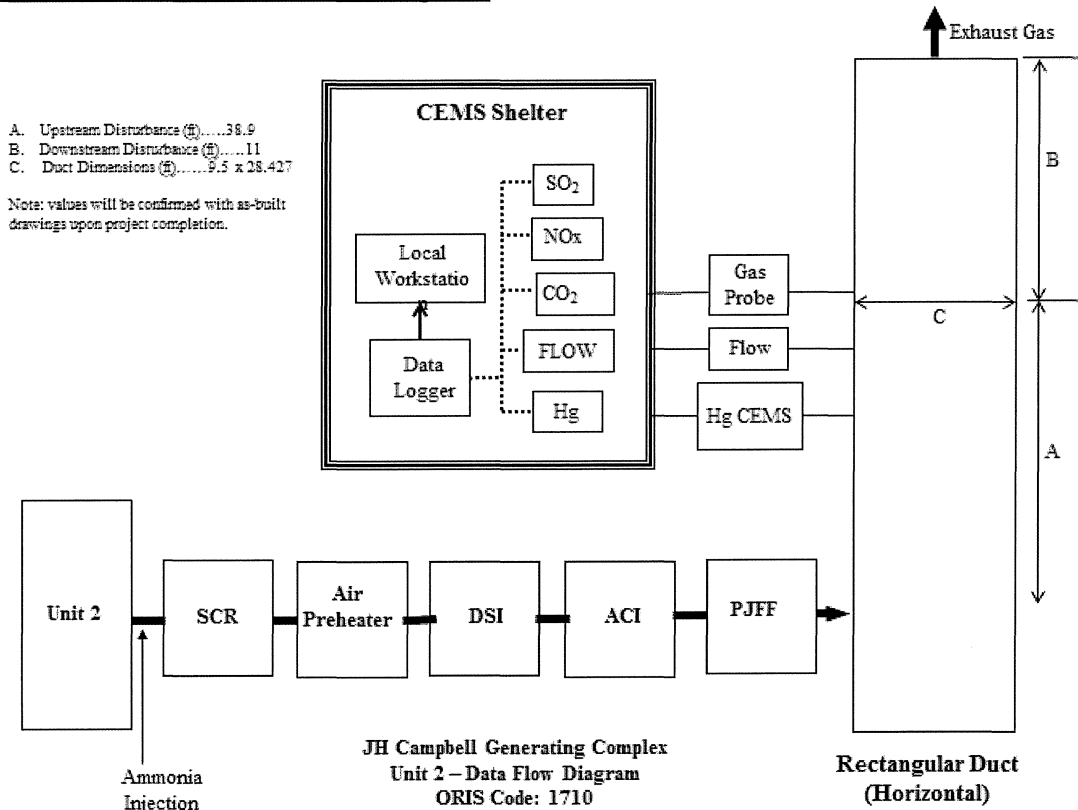

3.3 MATERIALS PROCESSED

Unit 2 is classified as a coal-fired unit not firing low rank virgin coal as described in Table 2 to Subpart UUUUU. The unit fired 100% western coal for this quarterly compliance test, however the unit is also capable of firing blends of eastern and low-sulfur western coal.

3.4 RATED CAPACITY

Unit 2 has a nominal heat input capacity of 3,560 mmBtu/hr and a gross electrical output of approximately 378 MWg while firing a blend of eastern and western coal. Unit 2 is capable of firing 100% bituminous (eastern) coal, 100% subbituminous (western) coal, and various mixtures of the two coal types. However, the unit is limited to approximately 300 MWg gross when firing only western coal, and the nominal heat input rating is achievable only when firing at least 40% eastern coal with all coal mills operating. The representative, normal fuel scenario for Unit 2 is 100% western coal. The boiler operates in a continuous manner in order to meet the electrical demands of Midcontinent Independent System Operator, Inc. (MISO) and Consumers Energy customers. EUBOILER2 is considered a baseload unit because it is designed to operate 24 hours a day, 365 days a year.

3.5 PROCESS INSTRUMENTATION

The process was continuously monitored by boiler operators, environmental technicians, and data acquisition systems during testing. One-minute data for the following parameters were collected during each PM and HCl test run, except for dry sorbent injection rate which is presented as an average injection rate in pounds per hour, for each test run:

- CO₂ (Vol-%)
- Load (MWg)
- Opacity (%)
- SO₂ Emission Rate (lb/mmBtu)
- Dry sorbent injection rate (lb/hr)

Due to the various instrumentation systems, the sampling times were correlated to instrumentation times. The RM testing and Dry Sorbent Injection (DSI) process feed rates data is recorded on Eastern Daylight Time (EDT), whereas other control equipment process instrumentation and CEMS records data on Eastern Standard Time (EST). During the test program, EDT was one hour later than EST (i.e., 8:00 am EDT = 7:00 am EST). Refer to Appendix D for operating data.

4.0 SAMPLING AND ANALYTICAL PROCEDURES

RCTS tested for PM and HCl using the USEPA test methods presented in Table 4-1. The sampling and analytical procedures associated with each parameter are described in the following sections.

**Table 4-1
Test Methods**

Parameter	Method	USEPA
		Title
Sample/traverse point locations	1	Sample and Velocity Traverses for Stationary Sources
Flow rate	2	Determination of Stack Gas Velocity and Volumetric Flow Rate (Type S Pitot Tube)
Molecular weight (O ₂ and CO ₂)	3A/3B ALT-123	Alternative Test Method for Diluent Measurement to Support Particulate Matter Testing Under 40 CFR 63, Subpart UUUUU
Moisture content	4	Determination of Moisture Content in Stack Gases
Filterable particulate matter	5	Determination of Particulate Matter Emissions from Stationary Sources
Emission rates	19	Sulfur Dioxide Removal and Particulate, Sulfur Dioxide and Nitrogen Oxides from Electric Utility Steam Generators
Hydrogen chloride	26A	Determination of Hydrogen Halide and Halogen Emissions from Stationary Sources Isokinetic Method

4.1 DESCRIPTION OF SAMPLING TRAIN AND FIELD PROCEDURES

The test matrix presented in Table 4-2 summarizes the sampling and analytical methods performed for the specified parameters during this test program.

**Table 4-2
Test Matrix**

Date (2019)	Run	Sample Type	Start Time (EDT)	Stop Time (EDT)	Test Duration (min)	EPA Test Method	Comment
Jun. 10	1	O ₂ /CO ₂ Moisture PM HCl	14:05	16:23	125	1	Isokinetic sampling from 25 traverse points collected 2.874 dscm of sample volume to meet LEE minimums of 2 dscm (PM) and 1.5 dscm (HCl)
Jun. 12	2		08:15	10:27	125	3A 3B ALT-123 4 5 19 26A	Isokinetic sampling from 25 traverse points collected 2.989 dscm of sample volume to meet LEE minimums of 2 dscm (PM) and 1.5 dscm (HCl).
	3		10:50	13:08	125		Isokinetic sampling from 25 traverse points collected 3.036 dscm of sample volume to meet LEE minimums of 2 dscm (PM) and 1.5 dscm (HCl)

4.1.1 SAMPLE LOCATION AND TRAVERSE POINTS (USEPA METHOD 1)

The number and location of traverse points for determining exhaust gas velocity and volumetric air-flow was determined in accordance with USEPA Method 1, *Sample and Velocity Traverses for Stationary Sources*. Five test ports are located in the horizontal plane

on east side of the 9.5 feet by 28 feet 5.1-inch rectangular duct. The duct has an equivalent duct diameter of 14 feet 2.9 inches. The ports are situated:

- Approximately 38.9 feet or 2.7 equivalent duct diameters downstream of a duct cross sectional area change flow disturbance, and
- Approximately 11 feet or 0.8 duct diameters upstream of flow disturbance caused by a change in duct cross sectional area as it enters the exhaust stack.

The sample ports are 6-inches in diameter and extend 22 inches beyond the duct wall. The area of the exhaust duct was calculated and the cross-sectional area divided into a number of equal rectangular areas based on distances to air flow disturbances. Flue gas was sampled for five minutes at each of the five traverse points from the five sample ports for a total of 25 sample points and 125 minutes. A drawing of the Unit 2 exhaust test port and traverse point locations is presented as Figure 4-1.

Figure 4-1. Unit 2 Duct Cross Section and Test Port/Traverse Point Detail

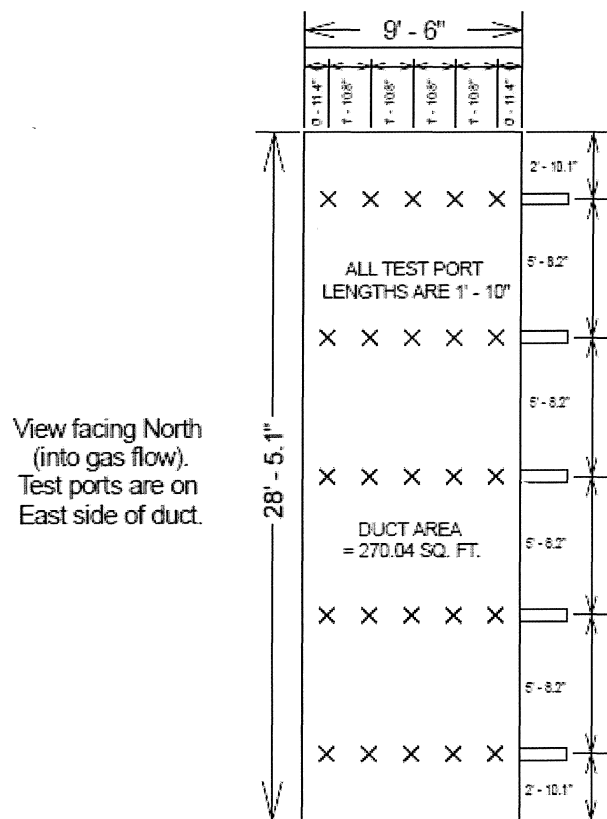

4.1.2 VELOCITY AND TEMPERATURE (USEPA METHOD 2)

The exhaust gas velocity and temperature were measured using USEPA Method 2, *Determination of Stack Gas Temperature and Velocity (Type S Pitot Tube)*. The pressure differential (ΔP) across the positive impact and negative static openings of the Pitot tube inserted in the exhaust duct at each traverse point were measured using an "S Type" (Stauscheibe or reverse type) Pitot tube connected to an appropriately sized oil filled inclined manometer. Exhaust gas temperatures were measured using a nickel-chromium/nickel-alumel "Type K" thermocouple and a temperature indicator. Refer to Figure 4-2 for the Method 2 Pitot tube, thermocouple, and inclined oil-filled manometer configuration.

Figure 4-2. Method 2 Sample Apparatus

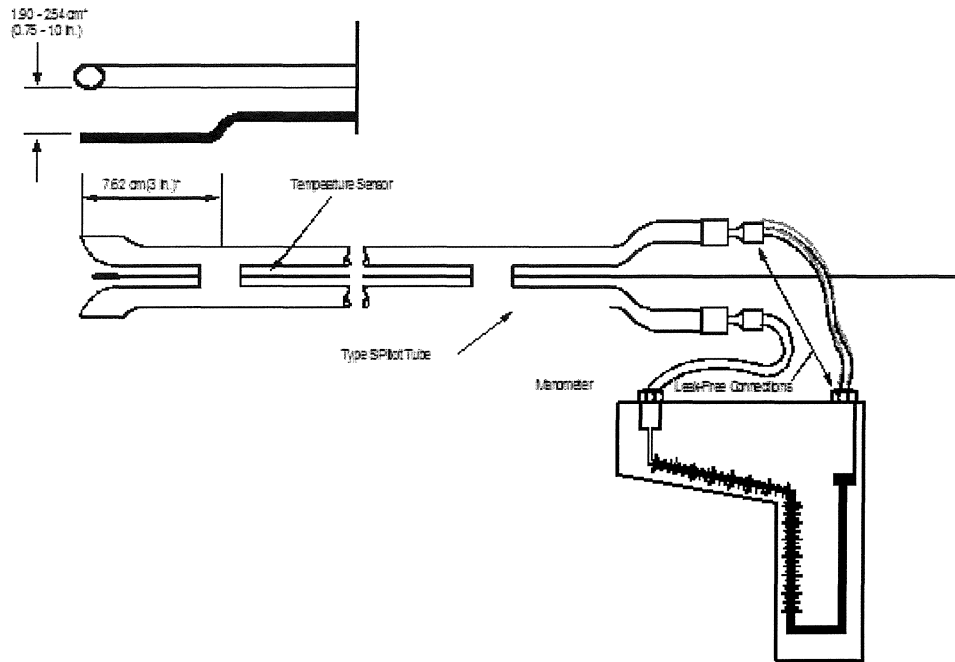

Appendix E of this report includes cyclonic flow test data as verification of the absence of cyclonic flow at the sample location. Method 1, § 11.4.2 states "if the average (null angle) is greater than 20°, the overall flow condition in the stack is unacceptable, and alternative methodology...must be used." The average null yaw angle measured at the Unit 2 exhaust on August 23, 2016 was 3.4°, thus meeting the less than 20° requirement and in the absence of ductwork and/or stack configuration changes, this null angle information is considered to be valid and additional cyclonic flow verification was not performed.

4.1.3 MOLECULAR WEIGHT (USEPA ALT-123)

The exhaust gas composition and molecular weight was measured using the sampling and analytical procedures of USEPA ALT-123, Alternative Test Method for Diluent Measurement to Support Particulate Matter Testing Under 40 CFR 63, Subpart UUUUU. ALT-123 combines the sample collection procedures of USEPA Method 3B, Gas Analysis for the Determination of Emission Rate Correction Factor or Excess Air with the analytical procedures of USEPA Method 3A, Oxygen and Carbon Dioxide Concentrations from Stationary Sources – (Instrumental Analyzer Procedure.) The flue gas oxygen and carbon dioxide concentrations were used to calculate molecular weight, flue gas velocity and emissions in lb/mmBtu.

Flue gas was extracted from the stack during each test from each of the 25 traverse points through a stainless steel lined probe and inert tubing into a flexible sample bag. The sample was then withdrawn from the flexible bag and conveyed into a multi gas analyzer that measured oxygen and carbon dioxide concentrations. Figure 4-3 depicts the ALT-123 sampling system.

Figure 4-3. USEPA Method 3A Sampling System

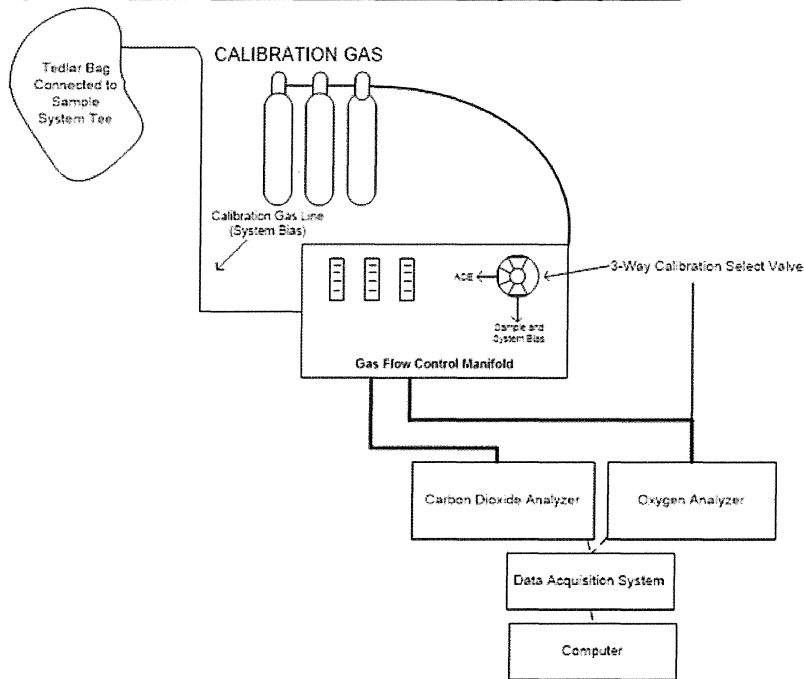

Prior to sampling flue gas, the analyzer was calibrated by performing a calibration error test where zero-, mid-, and high-level calibration gases were introduced directly to the analyzer. The calibration error check was performed to evaluate if the analyzer response was within $\pm 2.0\%$ of the calibration gas span. Analyzer system-bias and drift tests were performed by filling inert flexible sample bags with zero- and mid- or high- calibration gases and introducing these calibration standards into the gas analyzer to measure the ability of the system to respond to within ± 5.0 percent of span.

At the conclusion of the bag sample analysis, an additional system bias check was performed to evaluate the drift from the pre- and post-test system bias checks. The system-bias checks evaluated if the analyzer drift was within the allowable criterion of $\pm 3.0\%$ of span from pre- to post-test system bias checks. The measured oxygen and carbon dioxide concentrations were corrected for analyzer drift. Refer to Appendices B and E for analyzer calibration data and supporting documentation.

4.1.4 MOISTURE CONTENT (USEPA METHOD 4)

The exhaust gas moisture content was measured using USEPA Method 4, *Determination of Moisture in Stack Gases* in conjunction with the Method 5 and 26A sample apparatus. Sampled gas was drawn through a series of impingers immersed in an ice bath to condense and remove water from the flue gas. The amount of water condensed and collected in the impingers was measured gravimetrically and used to calculate the exhaust gas moisture content.

4.1.5 PARTICULATE MATTER AND HYDROGEN CHLORIDE (USEPA METHODS 5 AND 26A)

Filterable particulate matter and hydrogen chloride samples were collected isokinetically following the procedures of USEPA Method 5 (RM5), *Determination of Particulate Matter Emissions from Stationary Sources*, and USEPA Method 26A (RM26A), *Determination of Hydrogen Halide and Halogen Emissions from Stationary Sources Isokinetic Method*. RM 5

measures filterable particulate matter (aka PM, FPM) collected on a filter heated to $248\pm 25^{\circ}\text{F}$, while RM26A measures hydrogen halides collected in acidic absorbing solutions. These reference methods were combined into a single sample apparatus to collect PM and HCl samples simultaneously.

In letters to the USEPA dated February 10 and June 23, 2016, Consumers Energy requested and received approval for the use of RM5, rather than MATS5 when conducting quarterly PM testing to demonstrate compliance with MATS PM limits. Consumers Energy also requested and received approval to combine RM5 and RM26A in one apparatus when determining quarterly PM and HCl MATS compliance. As part of this approval, the USEPA included additional test specifications, the first of which required comparative RM5 and MATS5 testing consisting of three alternating runs for each of these methods at the same boiler operating condition (i.e., M5, MATS5, M5, MATS5, ...). This comparative approach would help determine if the RM5 front half filter temperature criterion of $248\pm 25^{\circ}\text{F}$ would bias PM loading, relative to the $320\pm 25^{\circ}\text{F}$ front half filter criterion in MATS5. The comparative RM5/MATS5 test program requested by USEPA was conducted at the source on August 23-24, 2016. The subsequent RM5/MATS5 results indicated there was no appreciable PM emission rate differences between the methodologies used, thus for all subsequent quarterly Unit 2 PM events, including this test event, RM5 methodology was employed.

The second approval stipulation for a combined RM5 and RM26A sampling apparatus required substituting the RM5 specific glass fiber filter without organic binders with a 99.95 percent efficient on 0.3 dioctyl phthalate (DOP) smoke particles, Teflon and borosilicate glass fiber PM filter. Furthermore, a filter temperature maintained between 248°F and 273°F was required during sampling as specified in RM26A. Therefore, a combined RM5 and RM26A sample apparatus was used for each test run during this event that met the prescribed USEPA stated filter and sampling temperature stipulations.

The RM5 and 26A sampling apparatus was setup and operated in accordance with method requirements. The flue gas was passed through a Teflon lined nozzle, heated probe, heated borosilicate glass microfiber reinforced with woven glass cloth and bonded with polytetrafluoroethylene (PTFE) filter, and into a series of impingers with the configuration presented in Table 4-3. The filter collected filterable particulate matter and halide salts while the impingers collected water vapor, hydrogen halides, and halogens. Figure 4-4 depicts the USEPA Method 5/26A sampling apparatus.

**Table 4-3
USEPA Methods 5 and 26A Impinger Configuration**

Impinger Order (Upstream to Downstream)	Impinger Type	Impinger Contents	Amount (gram)
1	Greenburg-Smith	0.1 N H_2SO_4	~100
2	Greenburg-Smith	0.1 N H_2SO_4	~100
3	Modified	0.1 N NaOH	~100
4	Modified	0.1 N NaOH	~100
5	Modified	Silica Gel Desiccant	~200-300

Prior to testing, representative velocity head and temperature data were reviewed to calculate an ideal nozzle diameter that would allow isokinetic sampling to be performed. The diameter of the selected nozzle was measured with calipers across three cross-sectional

chords and used to calculate its cross-sectional area. Prior to testing the nozzle was rinsed and brushed with deionized water and acetone, and connected to the sample probe.

The impact and static pressure openings of the Pitot tube were leak-checked at or above a velocity head of 3.0 inches of water for a minimum of 15 seconds. The sampling train was leak-checked by capping the nozzle and applying a vacuum of approximately 15 inches of mercury. The dry-gas meter was monitored for approximately 1 minute to verify the sample train leak rate was less than 0.02 cubic foot per minute (cfm). The sample probe was then inserted into the sampling port to begin sampling.

Ice and water were placed around the impingers and the probe and filter temperature were allowed to stabilize to between 248°F and 273°F. After the desired operating conditions were coordinated with the facility, testing was initiated. Stack and sampling apparatus parameters (e.g., flue gas velocity head, filter temperature) were monitored to calculate and sample at the isokinetic rate within $100 \pm 10\%$ for the duration of the test. Refer to Appendix B for field data sheets.

Figure 4-4. USEPA Methods 5 and 26A Sampling Apparatus

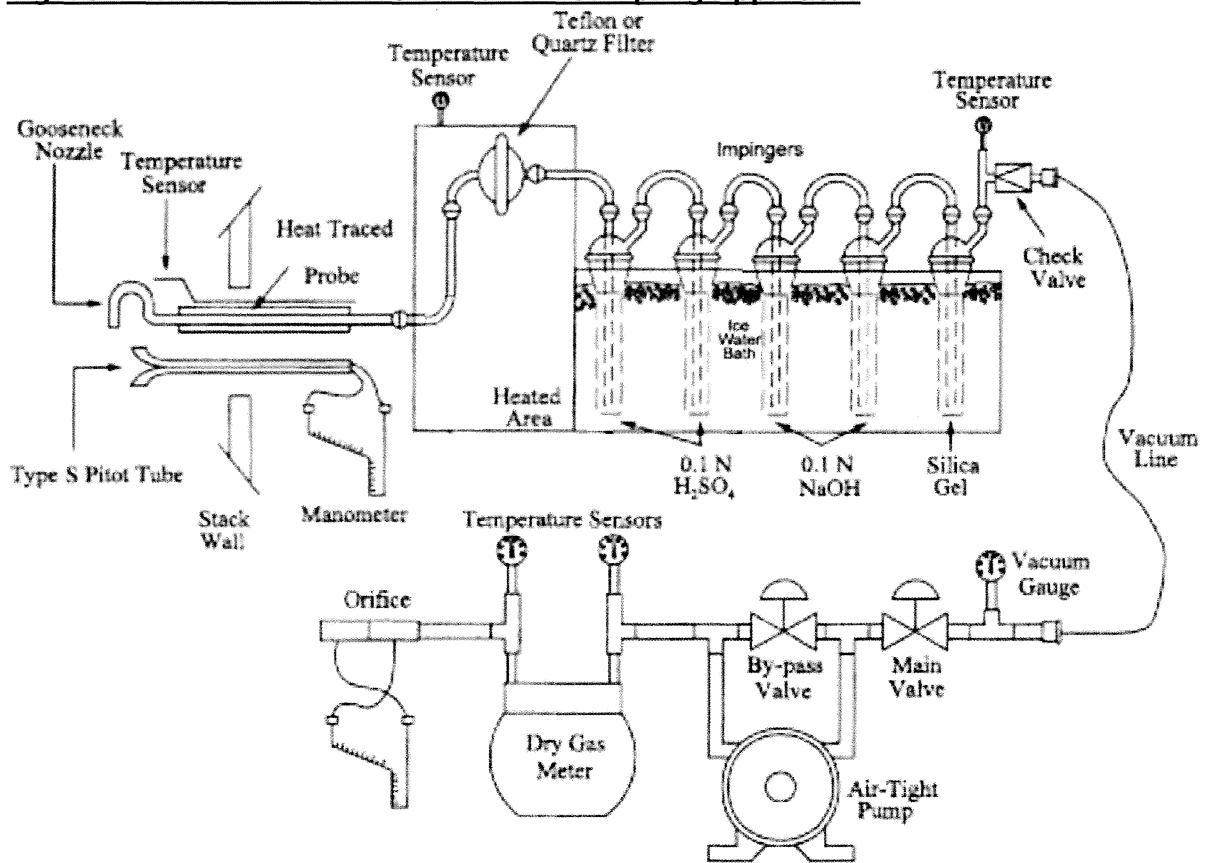

At the conclusion of a test run and post-test leak check, the sampling apparatus was disassembled and the impingers and filter housing were transported to the recovery area.

The filter was recovered from the filter housing and placed in a Petri dish, sealed with Teflon tape, and labeled as "FPM Container 1." The nozzle, probe liner, and the front half of the filter housing were triple rinsed with acetone to collect particulate matter. The rinsate was collected in pre-cleaned sample containers, sealed with Teflon tape, and labeled as "FPM Container 2." Prior to the start of subsequent runs, deionized, distilled water was used to final rinse the probe liner and nozzle; this rinse was discarded.

The weight of water vapor liquid collected in each impinger, including the silica gel impinger, was measured using an electronic scale. The volume of gas sampled and the difference between the pre-test and post-test impinger weights was used to calculate the moisture content of the sampled flue gas. The acidic and alkaline impinger contents were transferred to separate, labeled polyethylene sample containers. Each impinger was rinsed with deionized, distilled water and the rinsate was collected in the appropriate sample container. Approximately 20 milligrams of sodium thiosulfate was added to the sample storage bottle containing the 0.1 N NaOH impinger catch to assure a complete reaction with the hypohalous acid to form a second chlorine ion. The alkaline and acidic impinger contents were submitted to the laboratory. Since halogens are not part of this test program, the sample chain of custody directed the lab to not analyze the 0.1N NaOH samples unless notified. Refer to Figure 4-5 for the Methods 2 and 26A sample recovery scheme.

Figure 4-5. USEPA Methods 5 and 26A Sample Recovery Scheme

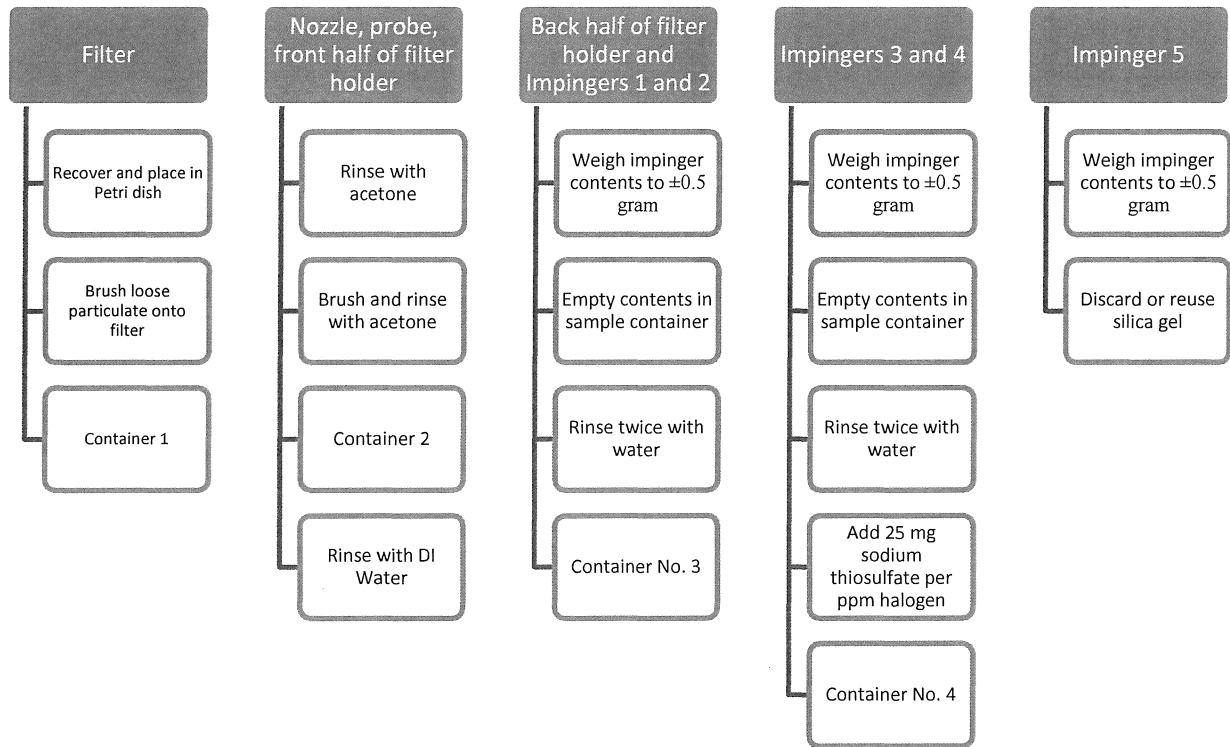

The sample containers, including filters, reagents, and water blanks, were transported to the laboratory for analysis. The chain of custody was prepared in accordance with ASTM D4840-99(2010) procedures and included the sample date, collection time, identification, and requested analysis. The sample analysis followed USEPA Method 5 and 26A procedures as summarized in the analytical scheme presented in Figure 4-6. Refer to Appendix C for laboratory data sheets.

Figure 4-6. USEPA Methods 5 and 26A Analytical Scheme

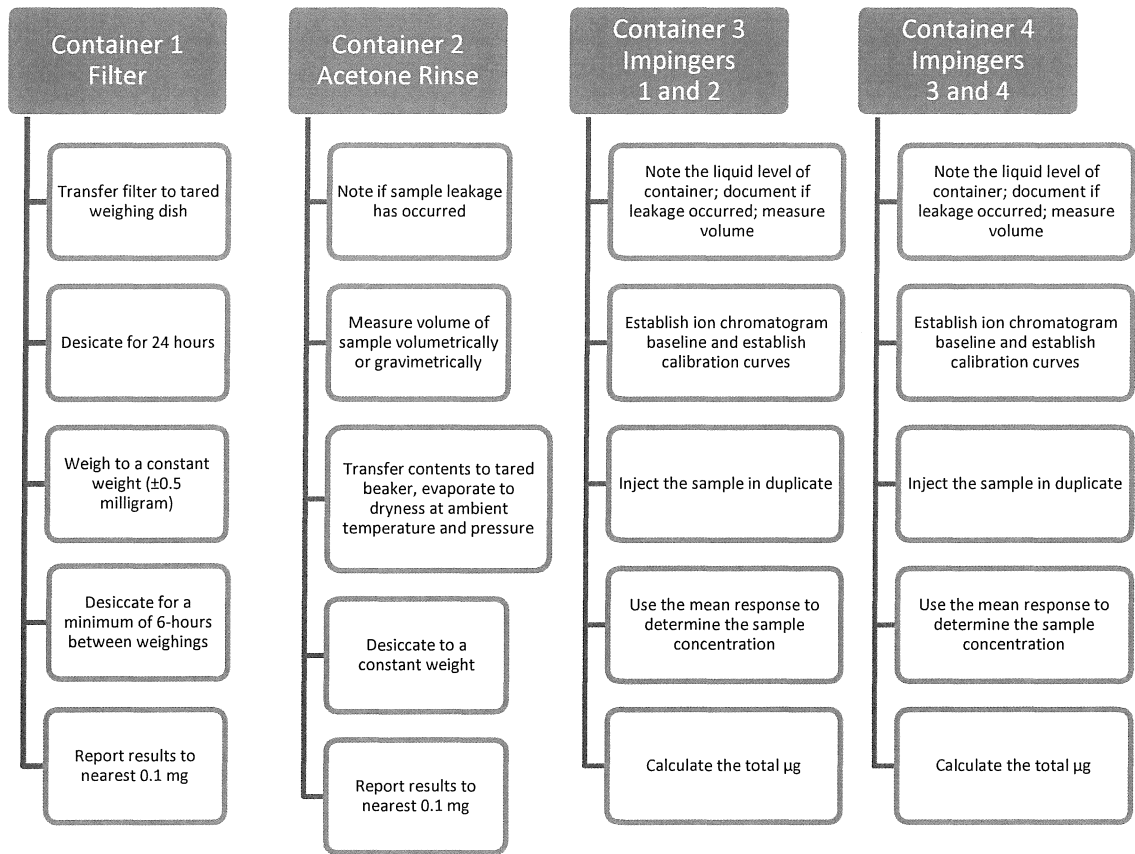

4.1.6 EMISSION RATES (USEPA METHOD 19)

USEPA Method 19, *Determination of Sulfur Dioxide Removal Efficiency and Particulate Matter, Sulfur Dioxide, and Nitrogen Oxide Emission Rates*, was used to calculate PM and HCl emission rates in units of lb/mmBtu. Measured carbon dioxide concentrations and F factors (ratios of combustion gas volumes to heat inputs) were used to calculate emission rates using equation 19-6 from the method. Figure 4-7 presents the equation used to calculate lb/mmBtu emission rate:

Figure 4-7. USEPA Method 19 Equation 19-6

$$E = C_d F_c \frac{100}{\%CO_{2d}}$$

Where:

- E = Pollutant emission rate (lb/mmBtu)
- C_d = Pollutant concentration, dry basis (lb/dscf)
- F_c = Volumes of combustion components per unit of heat content
1,840 scf CO₂/mmBtu for subbituminous coal from 40 CFR 75, Appendix F, Table 1
- %CO_{2d} = Concentration of carbon dioxide on a dry basis (% , dry)

5.0 TEST RESULTS AND DISCUSSION

The test program was performed to satisfy the first quarter 2019 PM and HCl performance test requirements and evaluate compliance with MATS as incorporated in MDEQ ROP MI-ROP-B2835-2013b. The Unit 2 PM and HCl 3-run average emissions measured during this event are less than or equal to 50 percent of the 0.030 lb/mmBtu PM and 0.0020 lb/mmBtu HCl applicable standards in Table 2 of the MATS rule, thus complying with applicable MATS and LEE limits for the 12th consecutive calendar quarter.

A summary of previous LEE evaluation tests is provided in Table 5-1.

**Table 5-1
MATS LEE PM and HCl Test Event Chronology, JHC Unit 2**

Performance Test			Compliance Quarter Event		PM Result (lb/mmBtu)	HCl Result (lb/mmBtu)
Year	Quarter	Date	PM	HCl		
2016	3	July 8, August 9	NA	1	NA	0.00050
		August 23-24	1	NA	0.0037	NA
2016	4	October 25	2	2	0.0028	0.00019
2017	1	April 11	3	3	0.0020	0.0001
2017	2	May 9	4	4	0.0025	<0.0001
2017	3	September 14-15	5	5	0.0006	<0.0001
2017	4	November 1	6	6	0.0005	<0.00005
2018	1	June 4-5	7	7	0.0011	0.00005
2018	2	June 27-28	8	8	0.0007	<0.00005
2018	3	September 26-27	9	9	0.0007	<0.00011
2018	4	December 3-4	10	10	0.0013	0.00006
2019	1	February 20-21	11	11	0.0005	<0.00004
2019	2	June 10, 12	12	12	0.0015	<0.00006

5.1 TABULATION OF RESULTS

Table 2-1 in Section 2 of this report summarizes the results and Appendix Table 1 contains a detailed tabulation of results, process operating conditions, and exhaust gas conditions.

5.2 SIGNIFICANCE OF RESULTS

The results of the testing indicate compliance with the MATS rule and ROP and demonstrates that EUBOILER2 operating at the J.H. Campbell Generating Station qualifies as a low-emitting EGU (LEE) for PM and HCl. Based on the results of the particulate matter and hydrogen chloride performance testing for the past 12 continuous quarters (refer to Table 5-1), where each emission test is in compliance with the LEE criteria, stack tests will be completed once every 36 months to demonstrate continued LEE status in accordance with 40 CFR 63.10000(c)(1)(iii).

5.3 VARIATIONS FROM SAMPLING OR OPERATING CONDITIONS

On the morning of June 11th, Unit 2 was unable to achieve an operating load of greater than 90% of maximum achievable on 100% western coal due to a coal pulverizer mill malfunction. The inability to achieve the necessary minimum load requirements precluded sampling on this day. By the morning of June 12th, site maintenance crews had repaired the mill and returned it to service, allowing the unit to achieve the necessary minimum load to continue testing.

No other sampling or operating condition variations were encountered during the test program.

5.4 PROCESS OR CONTROL EQUIPMENT UPSET CONDITIONS

The boiler and associated control equipment were operating under routine conditions and no upsets were encountered during testing.

5.5 AIR POLLUTION CONTROL DEVICE MAINTENANCE

No significant pollution control device maintenance occurred during the three months prior to the test. Optimization of the air pollution control equipment is a continuous process to ensure compliance with regulatory emission limits.

5.6 RE-TEST DISCUSSION

Based on the results of this test program, a re-test is not required. The next required quarterly MATS test event will be conducted in the second quarter of 2022.

5.7 RESULTS OF AUDIT SAMPLES

5.7.1 PERFORMANCE AUDIT SAMPLE

A performance audit (PA) sample (if available) for each test method employed is required, unless waived by the administrator for regulatory compliance purposes as described in 40 CFR 63.7(c)(2)(iii). A PA sample consists of blind audit sample(s), as supplied by an accredited audit sample provider (AASP), which are analyzed with the performance test samples in order to provide a measure of test data bias. Based on discussions with the EGLE, an audit sample shall be conducted once per year on either EUBOILER1 or EUBOILER2. An audit sample was ordered and analyzed for EUBOILER1 during the first quarter 2019 test event. The results of the audit sample analysis were within acceptable limits.

5.7.2 REFERENCE METHOD AUDITS

The USEPA reference methods performed state reliable results are obtained by persons equipped with a thorough knowledge of the techniques associated with each method. Factors with the potential to cause measurement errors are minimized by implementing quality control (QC) and assurance (QA) programs into the applicable components of field testing. QA/QC components were included in this test program. Table 5-2 summarizes the primary field quality assurance and quality control activities that were performed. Refer to Appendix E for supporting documentation.

Table 5-2
QA/QC Procedures

QA/QC Activity	Purpose	Procedure	Frequency	Acceptance Criteria
M1: Sampling Location	Evaluates if the sampling location is suitable for sampling	Measure distance from ports to downstream and upstream flow disturbances	Pre-test	≥2 diameters downstream; ≥0.5 diameter upstream.
M1: Duct diameter/dimensions	Verifies area of stack/duct is accurately measured	Review as-built drawings and field measurement	Pre-test	Field measurement agreement with as-built drawings
M2: Pitot tube calibration and standardization	Verifies construction and alignment of Pitot tube	Inspect Pitot tube, assign coefficient value	Pre-test and after each field use	Method 2 alignment and dimension requirements
M3A: Calibration gas standards	Ensures accurate calibration standards	Traceability protocol of calibration gases	Pre-test	Calibration gas uncertainty ≤2.0%
M3A: Calibration Error	Evaluates operation of analyzers	Introduce calibration gas directly into analyzers	Pre-test	±2.0% of the calibration span
M3A: System Bias and Analyzer Drift	Evaluates analyzer and sample system integrity and accuracy	Calibration gas introduced at the probe, upstream of all sample conditioning components	Pre-test and Post-test	Bias: ±5.0% of calibration span Drift: ±3.0% of calibration span
M3A: Multi-point integrated sample	Ensure representative sample collection	Insert probe into stack and purge sample system	Pre-test	Collect sample no closer to the stack wall than 1.0 meter; collect samples at traverse points
M4: Field balance calibration	Verify moisture measurement accuracy	Use Class 6 weight to check balance accuracy	Daily before use	The field balance must measure the weight within ±0.5 gram of the certified mass
M5/26A: nozzle diameter measurements	Verify nozzle diameter used to calculate sample rate	Measure inner diameter across three cross-sectional chords	Pre-test	3 measurements agree within ±0.004 inch
M5/26A: sample rate	Ensure representative sample collection	Calculate isokinetic sample rate	During and post-test	100±10% isokinetic rate
M26A: Apparatus Temperature	Ensures purge of acid gases in probe and on filter	Set probe & filter heat controllers to ≥248°F	Verify prior to and during each run	Apparatus temperature must be

**Table 5-2
QA/QC Procedures**

QA/QC Activity	Purpose	Procedure	Frequency	Acceptance Criteria
				≥248°F and ≤ 273°F
M5/26A: Sample volume	Ensure minimum required sample volumes collected	Record pre- and post-test dry gas meter volume reading	Post test	PM: ≥1 dscm LEE PM: ≥2 dscm HCl: ≥0.75 dscm LEE HCl: ≥1.5 dscm
M5/26A: Post-test leak check	Evaluate if system leaks biased the sample	Cap sample train; monitor DGM	Post-test	≤0.020 cfm
M5/26A: post-test meter audit	Evaluates sample volume accuracy	DGM pre- and post-test; compare calibration factors (Y and Yqa)	Pre-test Post-test	±5%

5.8 CALIBRATION SHEETS

Calibration sheets, including dry gas meter, gas protocol sheets, nozzle calibration and Pitot tube inspection sheets are presented in Appendix E. Analyzer quality control and assurance check information is presented in Appendix B, along with the field sheet information.

5.9 SAMPLE CALCULATIONS

Sample calculations and formulas used to compute emissions data are presented in Appendix A.

5.10 FIELD DATA SHEETS

Field data sheets are presented in Appendix B.

5.11 LABORATORY QUALITY ASSURANCE / QUALITY CONTROL PROCEDURES

The method specific quality assurance and quality control procedures in each method employed during this test program were followed, without deviation. Refer to Appendix C for the laboratory data sheets.

5.11.1 QA/QC BLANKS

Reagent and media blanks were analyzed for the parameters of interest. The results of the blanks analysis are presented in the Table 5-3. Laboratory QA/QC and blank results data are contained in Appendix C.

**Table 5-3
QA/QC Blanks**

Sample Identification	Result	Comment
Method 5 Acetone Blank	0.1 mg	Sample volume was 200 milliliters; Acetone blank corrections were applied based upon a default 0.001% of the acetone rinse weight
Method 5 Filter Blank	0.1 mg	Reporting limit is 0.1 milligrams. Blank corrections were not applied
Method 26A 0.1 N H2SO4 Reagent Blank	<166.0 µg	Blank corrections were not applied
Method 26A Water Blank	<61.0 µg	Blank corrections were not applied