

Consumers Energy

Count on Us®

RECEIVED

JUL 03 2017

AIR QUALITY DIV.

**Particulate Matter and
Hydrogen Chloride
40 CFR 63, Subpart UUUUU
Test Report**

EUBOILER1

**Consumers Energy Company
J.H. Campbell Plant
17000 Crosswell Street
West Olive, Michigan 49460
SRN: B2835
FRS: 110000411108**

Test Date: May 11, 2017

June 29, 2017

**Test Performed by the Consumers Energy Company
Regulatory Compliance Testing Section – Air Emissions Testing Body
Laboratory Services
Work Order No. 26701577
Revision 0**

EXECUTIVE SUMMARY

Consumers Energy Regulatory Compliance Testing Section (RCTS) conducted filterable particulate matter (PM) and hydrogen chloride (HCl) testing of the dedicated exhaust of coal-fired boiler EUBOILER1 (Unit 1) operating at the J.H. Campbell Generating Station in West Olive, Michigan. EUBOILER1 is a coal-fired electric utility steam generating unit (EGU) that turns a turbine connected to an electricity producing generator. The test program was performed to satisfy the 2017 second quarter PM and HCl performance testing requirements and evaluate compliance with 40 CFR 63, Subpart UUUUU, “National Emission Standards for Hazardous Air Pollutants: Coal- and Oil-Fired Electric Utility Steam Generating Units,” (aka Mercury and Air Toxics Rule [MATS]) as incorporated in the Michigan Department of Environmental Quality (MDEQ) Renewable Operating Permit (ROP) MI-ROP-B2835-2013a.

Triplicate 125-minute PM and 120-minute HCl test runs were conducted on May 11, 2017 following the procedures in United States Environmental Protection Agency (USEPA) Reference Methods (RM) 1, 2, 3A, 4, 5, 19, and 26 in 40 CFR 60, Appendix A. There were no deviations from the approved stack test protocol or the associated USEPA Reference Methods. During testing, Unit 1 was operated within the maximum normal operating load requirement range of 90 and 110 percent of design capacity as specified in 40 CFR 63.10007(2). The Unit 1 PM and HCl results are summarized in the following table.

Summary of PM and HCl Test Results

Parameter	Units	Run			Average	Emission Limit	
		1	2	3		MATS	MATS LEE [†]
PM	lb/mmBtu	0.0035	0.0028	0.0031	0.0031	0.030	0.015
HCl		<0.0001	<0.0001	<0.0001	<0.0001	0.0020	0.0010

[†] Applicable emission limit to qualify for low emitting EGU (LEE) status

The results of the testing indicate the individual and 3-run average PM and HCl results are in compliance with applicable limits and with the low emitting EGU (LEE) PM and HCl emission limits for Unit 1 under the MATS regulation.

Detailed results are presented in Tables 1 and 2. Sample calculations and field data sheets are presented in Appendices A and B. Laboratory data is presented in Appendix C. Boiler operating data and supporting information are provided in Appendices D and E.

1.0 INTRODUCTION

Consumers Energy Regulatory Compliance Testing Section (RCTS) conducted filterable particulate matter (PM) and hydrogen chloride (HCl) testing of the dedicated exhaust of coal-fired boiler EUBOILER1 (Unit 1) operating at the J.H. Campbell Generating Station in West Olive, Michigan. EUBOILER1 is a coal-fired electric utility steam generating unit (EGU) that turns a turbine connected to an electricity producing generator. The test program was performed to satisfy the 2017 second quarter PM and HCl performance testing requirements and evaluate compliance with 40 CFR 63, Subpart UUUUU, “National Emission Standards for Hazardous Air Pollutants: Coal- and Oil-Fired Electric Utility Steam Generating Units,” (aka Mercury and Air Toxics Rule [MATS]) as incorporated in the Michigan Department of Environmental Quality (MDEQ) Renewable Operating Permit (ROP) MI-ROP-B2835-2013a.

A test protocol was submitted to the MDEQ on September 23, 2016 and subsequently approved by Mr. Tom Gasloli, Environmental Quality Analyst, in his letter dated October 18, 2016. The letter reflects a standing approval for all quarterly MATS tests as long as no modifications from the original protocol are required, as was the case for this test event.

The testing evaluated compliance with the applicable emission limits summarized in Table 1-1 and is being used to support qualification as a low emitting electric generating unit (LEE) for PM and HCl.

Table 1-1
MATS Emission Limits

Parameter	Emission Limit	Units	Applicable Requirement
PM	0.030	lb/mmBtu	Table 2 to Subpart UUUUU of Part 63— Emission Limits for Existing EGU’s
HCl	0.0020		

lb/mmBtu: pound per million British thermal unit heat input

Qualification of LEE status as defined within MATS requires quarterly sampling over a period of three consecutive years. The results of each quarterly test must be less than or equal to 50 percent of the applicable standard listed in Table 2 of the MATS rule, equating to 0.015 lb/mmBtu for PM and 0.0010 lb/mmBtu for HCl.

The tests were conducted on May 11, 2017 following the procedures in United States Environmental Protection Agency (USEPA) Reference Methods (RM) 1, 2, 3A, 4, 5, 19, and 26 in 40 CFR 60, Appendix A.

1.1 CONTACT INFORMATION

Table 1-2 presents the EGU test program organization, major lines of communication, and names and phone numbers of responsible individuals.

Table 1-2
Contact Information

Program Role	Contact	Address
State Regulatory Administrator	Ms. Karen Kajiya-Mills Technical Programs Unit Manager 517-335-4874 Kajiya-Millsk@michigan.gov	Michigan Department of Environmental Quality Technical Programs Unit 525 W. Allegan, Constitution Hall, 2 nd Floor S Lansing, Michigan 48933
Responsible Official	Mr. Norman J. Kapala Executive Director of Coal Generation 616-738-3200 Norman.Kapala@cmsenergy.com	Consumers Energy Company J.H. Campbell Power Plant 17000 Croswell Street West Olive, Michigan 49460
Test Facility	Mr. Joseph J. Firlit Sr. Engineering Tech Analyst Lead 616-738-3260 Joseph.Firlit@cmsenergy.com	Consumers Energy Company J.H. Campbell Power Plant 17000 Croswell Street West Olive, Michigan 49460
Test Facility	Mr. Michael T. Rabideau Senior Technician 616-738-3273 Michael.Rabideau@cmsenergy.com	Consumers Energy Company J.H. Campbell Power Plant 17000 Croswell Street West Olive, Michigan 49460
Test Team Representative	Mr. Thomas R. Schmelter, QSTI Engineering Technical Analyst 616-738-3334 Thomas.Schmelter@cmsenergy.com	Consumers Energy Company L&D Training Center 17010 Croswell Street West Olive, Michigan 49460
Laboratory	Mr. Gordon Cattell 517-788-2334 Sr. Laboratory Tech Analyst Lead Gordon.Cattell@cmsenergy.com	Consumers Energy Company Laboratory Services 135 W Trail Street Jackson, Michigan 49201

RECEIVED

JUL 03 2017

AIR QUALITY DIV.

2.0 SUMMARY OF RESULTS

2.1 OPERATING DATA

During the performance test, the boiler fired 100% western coal and was operated at maximum normal operating load conditions. 40 CFR 63.10007(2) states the maximum normal operating load is generally between 90 and 110 percent of design capacity but should be representative of site specific normal operations. The performance testing was performed while the boiler was operating within the range of 271 MWg to 277 MWg (99-101% of the achievable capacity).

Refer to Attachment D for detailed operating data, which was recorded in Eastern Standard Time. Note the time convention for the reference method (RM) testing was Eastern Daylight Savings Time (EDT); therefore, there is a one hour offset between the RM time stamps and continuous emissions monitoring system (CEMS)/process data time stamps.

2.2 APPLICABLE PERMIT INFORMATION

The J.H. Campbell generating station has State of Michigan Registration Number (SRN) B2835 and operates in accordance with air permit MI-ROP-B2835-2013a. The air permit incorporates state and federal regulations, and the USEPA has assigned the facility a Federal Registry Service (FRS) identification number of 110000411108. EUBOILER1 is the emission unit source identification in the permit and is included in the FGBOILER12 flexible group. Incorporated within the permit are the applicable requirements of 40 CFR 63, Subpart UUUUU – National Emission Standards for Hazardous Air Pollutants: Coal- and Oil-fired Electric Utility Steam Generating Units.

In addition to the state issued air permit, Consumers Energy operates Unit 1 in accordance with the requirements in Consent Decree (CD), Civil Action No.: 14-13580, entered between Consumers Energy, the United States Environmental Protection Agency (EPA), and the United States Department of Justice (DOJ) on November 4, 2014.

2.3 RESULTS

The results of the testing indicate the individual and 3-run average PM and HCl results are in compliance with applicable limits and with LEE PM and HCl emission limits under the MATS regulation. This was the 14th quarterly performance test demonstrating LEE status for EUBOILER1. Refer to Table 2-1 for a summary of the PM and HCl test results.

Table 2-1
Summary of PM and HCl Test Results

Parameter	Units	Run			Average	Emission Limit	
		1	2	3		MATS	MATS LEE [†]
PM	lb/mmBtu	0.0035	0.0028	0.0031	0.0031	0.030	0.015
HCl		<0.0001	<0.0001	<0.0001	<0.0001	0.0020	0.0010

[†] Applicable emission limit to qualify for low emitting EGU (LEE) status

HCl was not detected or reported by the laboratory as below the quantitation limit in the samples collected for each of the three test runs. The HCl results calculated in this report are based upon the reported quantitation limit (QL), as required by 40 CFR 63.10007(e)(1); however, the actual HCl emissions are less than the QL.

Detailed results are presented in Tables 1 and 2. Sample calculations and field data sheets are presented in Appendices A and B. Laboratory data is presented in Appendix C. Boiler operating data and supporting information are provided in Appendices D and E.

3.0 SOURCE DESCRIPTION

EUBOILER1 is a coal-fired EGU that turns a turbine connected to an electricity producing generator.

3.1 PROCESS

Unit 1 is a dry bottom tangentially-fired boiler constructed in 1958 which combusts pulverized subbituminous coal as the primary fuel and oil as an ignition/flame stabilization fuel. The source classification code (SCC) is 10100226. Coal is fired in the furnace where the combustion heats water within boiler tubes producing steam. The steam turns a turbine that is connected to an electricity producing generator. The electricity is routed through the transmission and distribution system to consumers.

3.2 PROCESS FLOW

The flue gas generated through coal combustion is controlled by multiple pollution control devices. The unit is currently equipped with low nitrogen oxides (NO_x) burners and over fire air (OFA) for NO_x control, a dry sorbent (lime) injection (DSI) system for control of sulfur dioxides (SO₂) and other acid gasses, an activated carbon injection (ACI) system for mercury (Hg) reduction, and a pulse jet fabric filter (PJFF) baghouse to control particulate matter emissions. Clean flue gas is exhausted to atmosphere through an approximately 400-foot high stack, which is shared with EUBOILER2. Refer to Figure 3-1 for the Unit 1 Data Flow Diagram.

Figure 3-1. Unit 1 Data Flow Diagram

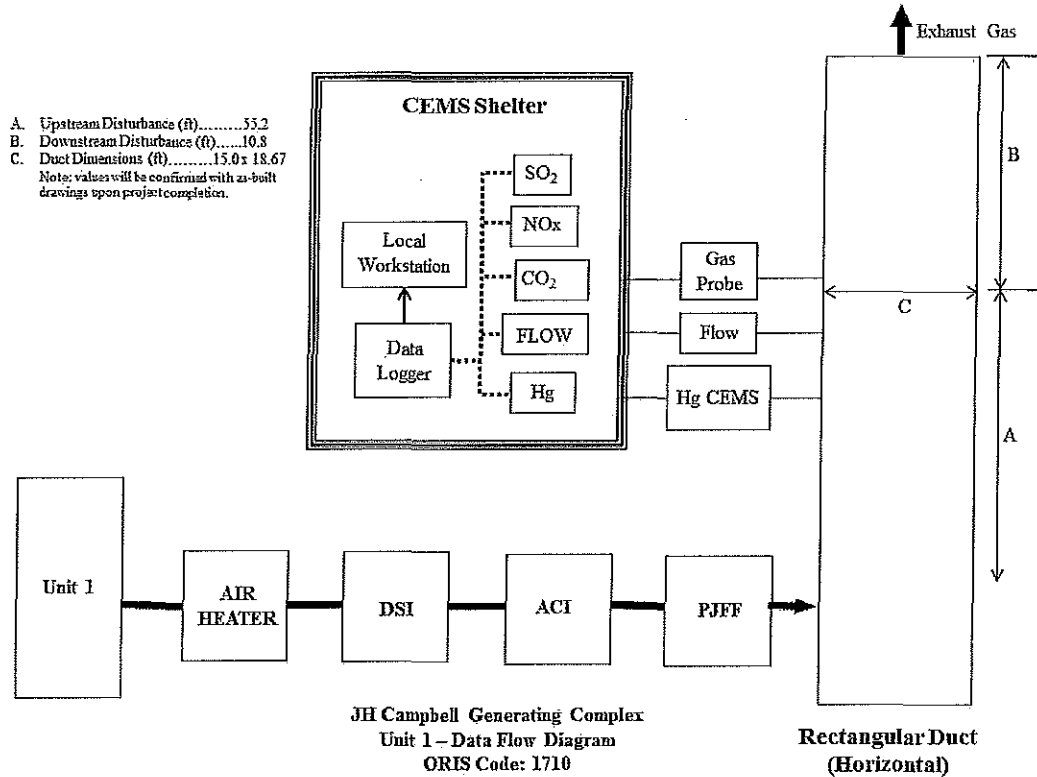

Note: DSI injection lances can be utilized either upstream or downstream of the air heater inlet. For this test, injection was post air heater.

3.3 MATERIALS PROCESSED

The Unit 1 boiler is classified as a coal-fired unit not firing low rank virgin coal as described in Table 2 to Subpart UUUUU. For this quarterly compliance test, Unit 1 was burning 100% western subbituminous coal.

3.4 RATED CAPACITY

Unit 1 has a nominally rated heat input capacity of 2,490 mmBtu/hr and can generate a gross electrical output of approximately 274 gross megawatts (MWg). The boiler operates in a continuous manner in order to meet the electrical demands of Midcontinent Independent System

Operator, Inc. (MISO) and Consumers Energy customers. EUBOILER1 is considered a baseload unit because it is designed to operate 24 hours a day, 365 days a year.

3.5 PROCESS INSTRUMENTATION

The process was continuously monitored by boiler operators, environmental technicians, and data acquisition systems during testing. One-minute data for the following parameters were collected during each PM and HCl test runs: Load (MWg), opacity (%), and dry sorbent injection rate (lb/hr). Due to the various instrumentation systems, the sampling times were correlated to instrumentation times. The control equipment process instrumentation and reference method data is recorded on Eastern Daylight Time (EDT), whereas, the continuous emissions monitoring systems records data on Eastern Standard Time (EST). During the test program, EDT was one hour later than EST. (i.e., 8:00 am EDT = 7:00 am EST). Refer to Appendix D for operating data.

4.0 SAMPLING AND ANALYTICAL PROCEDURES

Consumers Energy RCTS tested for PM and HCl emissions using the USEPA test methods presented in Table 4-1. The sampling and analytical procedures associated with each parameter are described in the following sections.

**Table 4-1
 Test Methods**

Parameter	USEPA	
	Method	Title
Sampling location	1	Sample and Velocity Traverses for Stationary Sources
Traverse points	2	Determination of Stack Gas Velocity and Volumetric Flow Rate (Type S Pitot Tube)
Molecular weight (O ₂ and CO ₂)	3A	Determination of Oxygen and Carbon Dioxide Concentrations in Emissions from Stationary Sources (Instrumental Analyzer Procedure)
Moisture	4	Determination of Moisture Content in Stack Gases
Filterable particulate matter	5	Determination of Particulate Matter Emissions from Stationary Sources
Pollutant emission rate	19	Determination of Sulfur Dioxide Removal Efficiency and Particulate Matter, Sulfur Dioxide, and Nitrogen Oxide Emission Rates
Hydrogen chloride	26	Determination of Hydrogen Chloride Emissions from Stationary Sources

4.1 DESCRIPTION OF SAMPLING TRAIN AND FIELD PROCEDURES

The test matrix presented in Table 4-2 summarizes the sampling and analytical methods performed for the specified parameters during this test program. The PM and HCl run start times are offset due to the availability of test ports to accommodate both sample apparatus. PM sampling within the first test port needed to be completed before that port was available to conduct the HCl sampling.

**Table 4-2
 Test Matrix**

Date (2017)	Run	Sample Type	Start Time (DST)	Stop Time (DST)	Test Duration (min)	EPA Test Method	Comment
May 11	1	PM	7:40	9:59	125	M5	25 traverse points; isokinetic sampling; obtained minimum LEE sample volume of 2 dscm
		HCl	8:21	10:21	120	M26	Minimum LEE sample volume of 240 L was collected
	2	PM	10:29	12:47	125	M5	25 traverse points; isokinetic sampling; obtained minimum LEE sample volume of 2 dscm
		HCl	11:05	13:05	120	M26	Minimum LEE sample volume of 240 L was collected
	3	PM	13:10	15:28	125	M5	25 traverse points; isokinetic sampling; obtained minimum LEE sample volume of 2 dscm
		HCl	13:45	15:45	120	M26	Minimum LEE sample volume of 240 L was collected

Note: Appendix D presents Operating Data for the duration of the test period, inclusive of the time during test port changes, between run start and stop times.

4.1.1 Sample Location and Traverse Points (USEPA Method 1)

The number and location of traverse points for determining exhaust gas velocity and volumetric air-flow was determined in accordance with USEPA Method 1, *Sample and Velocity Traverses for Stationary Sources*. Five test ports are located in the horizontal plane on east side of the 15 feet by 18 feet 8-inch rectangular duct. The duct has an equivalent duct diameter of 16 feet 7.6 inches. The ports are situated:

- Approximately 55.2 feet or 3.3 duct diameters downstream of a duct diameter change flow disturbance, and
- Approximately 10.8 feet or 0.6 duct diameters upstream of flow disturbance caused by a curve in the duct as it enters the exhaust stack.

The sample ports are 6-inches in diameter and extend 24 inches beyond the stack wall. The area of the exhaust duct was calculated and the cross-sectional area divided into a number of equal rectangular areas based on distances to air flow disturbances. Flue gas for particulate matter was sampled for five minutes at each of the five traverse points from the five sample ports for a total of 25 sample points and 125 minutes. The HCl samples were collected from the bottom port at a single sample point approximately 1 meter from the stack wall for 120 minutes during each test. A drawing of the Unit 1 exhaust test port and traverse point locations is presented as Figure 4-1.

Figure 4-1. Unit 1 Duct Cross Section and Test Port/Traverse Point Detail

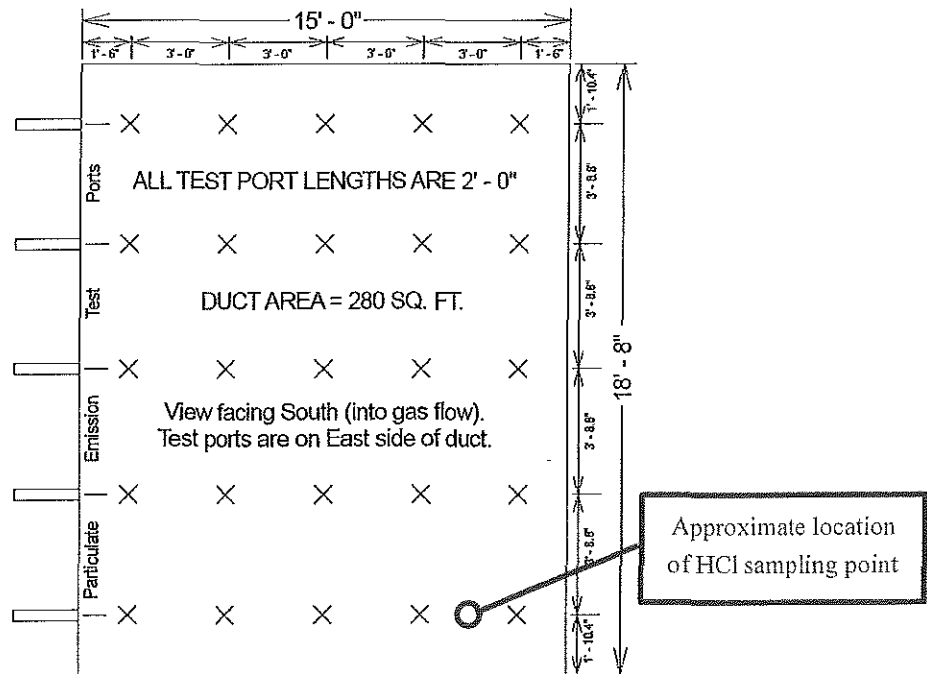

4.1.2 Velocity and Temperature (USEPA Method 2)

The exhaust gas velocity and temperature were measured using USEPA Method 2, *Determination of Stack Gas Temperature and Velocity (Type S Pitot Tube)*. The pressure differential (ΔP) across the positive impact and negative static openings of the Pitot tube inserted in the exhaust duct at each traverse point were measured using an "S Type" (Stauscheibe or

reverse type) Pitot tube connected to an appropriately sized oil filled inclined manometer. Exhaust gas temperatures were measured using a nickel-chromium/nickel-alumel “Type K” thermocouple and a temperature indicator. Refer to Figure 4-2 for the Method 2 Pitot tube, thermocouple, and inclined oil-filled manometer configuration.

Figure 4-2. Method 2 Sample Apparatus

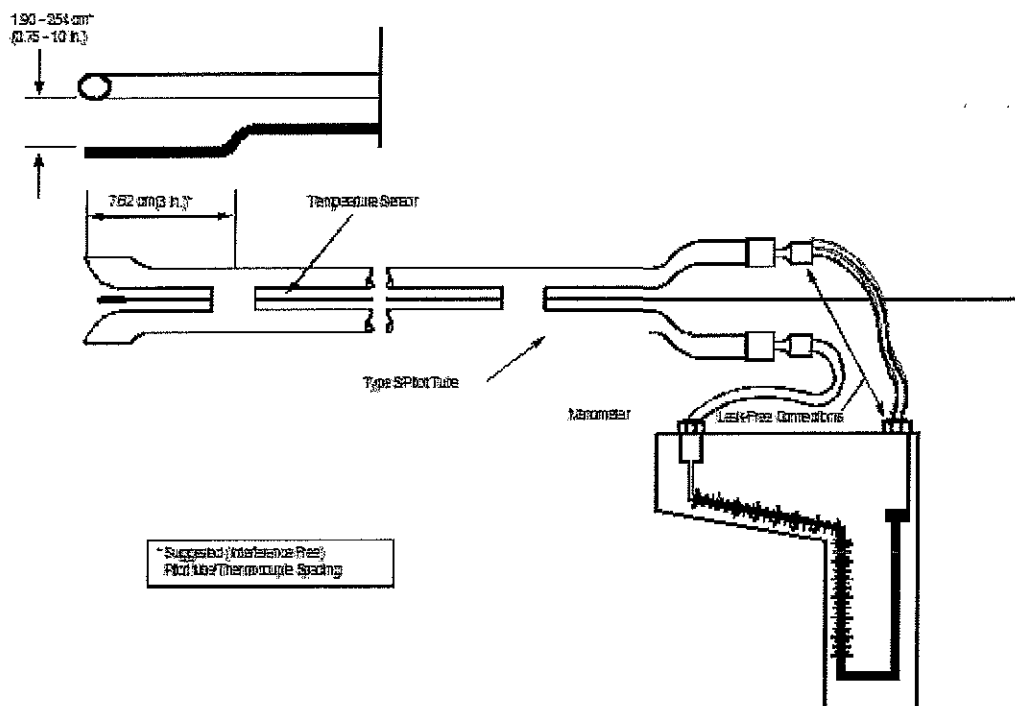

Appendix B of this report includes cyclonic flow test data as verification of the absence of cyclonic flow at the sample location. Method 1, § 11.4.2 states “if the average (null angle) is greater than 20°, the overall flow condition in the stack is unacceptable, and alternative methodology...must be used.” The average null yaw angle measured at the Unit 1 exhaust on September 22, 2016, was measured to be 2.4°, thus meeting the less than 20° requirement and in the absence of ductwork and/or stack configuration changes, this null angle information is considered to be valid and additional cyclonic flow verification was not performed.

4.1.3 Molecular Weight (USEPA Method 3A)

The exhaust gas composition and molecular weight was measured using the sampling and analytical procedures of USEPA Method 3A, *Determination of Oxygen and Carbon Dioxide Concentrations in Emissions from Stationary Sources (Instrumental Analyzer Procedure)*. The

flue gas oxygen and carbon dioxide concentrations were used to calculate molecular weight, flue gas velocity, emissions in lb/mmBtu, and/or lb/1,000 lbs corrected to 50% excess air.

Flue gas was extracted from the stack through a heated stainless steel lined probe and Teflon® sample line into a flexible sample bag. The sample was withdrawn from the flexible bag and conveyed through a gas conditioning system to remove water content before entering paramagnetic and infrared gas analyzers that measure oxygen and carbon dioxide concentrations. Figure 4-3 depicts the Method 3A sampling system.

Figure 4-3. Method 3A Sampling System

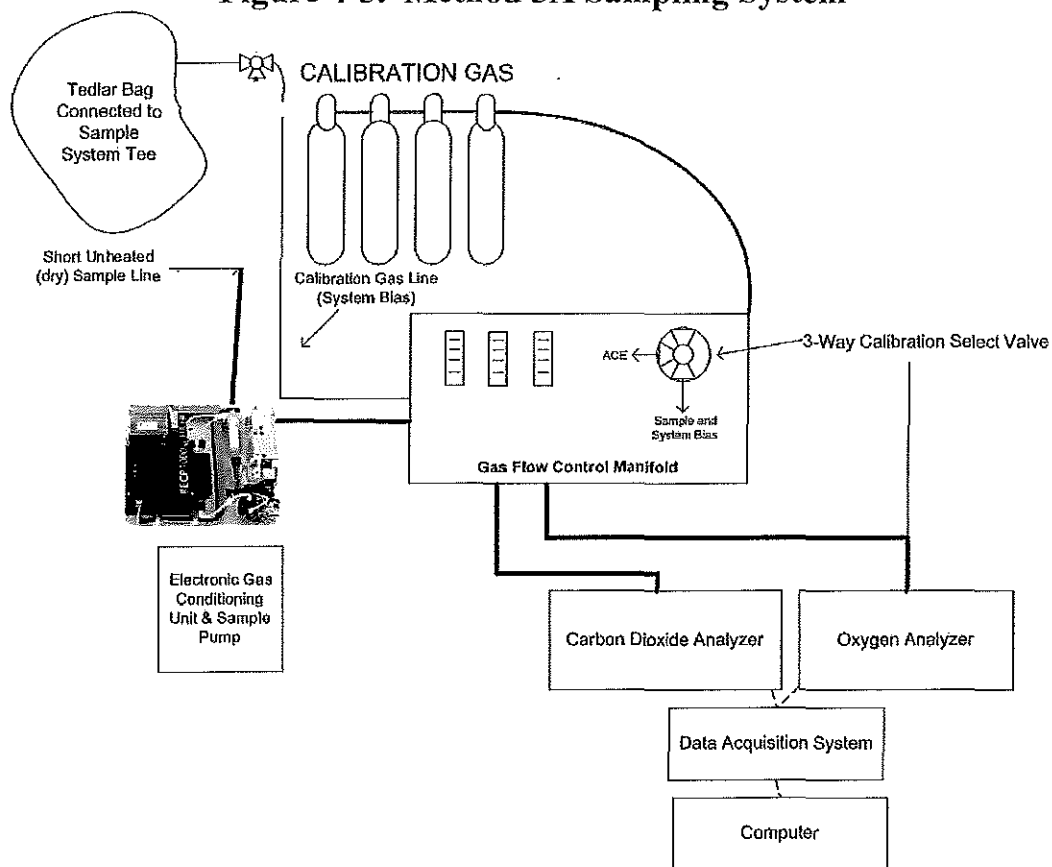

Prior to sampling flue gas, the analyzers were calibrated by performing a calibration error test where zero-, mid-, and high-level calibration gases are introduced to the back of the analyzers. The calibration error check was performed to evaluate if the analyzers response was within $\pm 2.0\%$ of the calibration gas span. A system-bias and drift test was performed where the zero-

and mid- or high- calibration gases are introduced at the inlet to the gas conditioner to measure the ability of the system to respond to within ± 5.0 percent of span.

In lieu of performing a stratification test, the flexible bag samples were collected throughout the particulate matter tests at each of the 25 traverse points.

At the conclusion of the bag sample analysis, an additional system bias check was performed to evaluate the drift from the pre- and post-test system bias checks. The system-bias checks evaluated if the analyzers drift is within the allowable criterion of $\pm 3.0\%$ of span from pre- to post-test system bias checks. The measured oxygen and carbon dioxide concentrations were corrected for analyzer drift. Refer to Appendix E for analyzer calibration supporting documentation.

4.1.4 Moisture Content (USEPA Method 4)

The exhaust gas moisture content was measured using USEPA Method 4, *Determination of Moisture in Stack Gases* in conjunction with the Method 5 sample apparatus. Sampled gas was drawn through a series of impingers immersed in an ice bath to condense and remove water from the flue gas. The amount of water condensed and collected in the impingers was measured gravimetrically and used to calculate the exhaust gas moisture content.

4.1.5 Particulate Matter (USEPA Method 5)

Filterable particulate matter samples were collected isokinetically by withdrawing a sample of the flue gas through a nozzle, heated probe, and filter following the procedures of USEPA Method 5 (RM5), *Determination of Particulate Matter Emissions from Stationary Sources*. USEPA Method 5 measures filterable particulate matter (aka PM, FPM) collected on a filter heated to $248 \pm 25^\circ\text{F}$.

Comparison testing between RM5 and MATS 5, where the front half filter temperature is heated and maintained to $320 \pm 25^\circ\text{F}$, was conducted at the source on August 2 and 3, 2016 and indicated no appreciable difference between the particulate matter emission rates measured by the two different sampling techniques. Based on the August 2 and 3, 2016 comparison test results, the test team used RM5 for the May 11, 2017 test, as approved by the USEPA in a letter dated April 12, 2016.

The RM5 sampling apparatus was setup and operated in accordance with the method. The flue gas was passed through a nozzle, heated probe, quartz-fiber filter, and into a series of impingers with the configuration presented in Table 4-3. The filter collects filterable particulate matter while the impingers collect water vapor. Figure 4-4 depicts the USEPA Method 5 sampling train.

Table 4-3
Method 5 Impinger Configuration

Impinger Order (Upstream to Downstream)	Impinger Type	Impinger Contents	Amount (gram)
1	Modified	Water	100
2	Greenburg-Smith	Water	100
3	Modified	Empty	0
4	Modified	Silica gel desiccant	~200-300

Prior to testing, representative velocity head and temperature data were reviewed to calculate an ideal nozzle diameter that would allow isokinetic sampling to be performed. The diameter of the selected nozzle was measured with calipers across three cross-sectional chords and used to calculate its cross-sectional area. Prior to testing the nozzle was rinsed and brushed with deionized water and acetone, and connected to the sample probe.

The impact and static pressure openings of the Pitot tube were leak-checked at or above a velocity head of 3.0 inches of water for a minimum of 15 seconds. The sampling train was leak-checked by capping the nozzle and applying a vacuum of approximately 15 inches of mercury. The dry-gas meter was monitored for approximately 1 minute to verify the sample train leak rate was less than 0.02 cubic foot per minute (cfm). The sample probe was then inserted into the sampling port to begin sampling.

Ice and water were placed around the impingers and the probe and filter temperature were allowed to stabilize to 248±25°F. After the desired operating conditions were coordinated with the facility, testing was initiated. Stack and sampling apparatus parameters (e.g., flue gas velocity head, filter temperature) were monitored to calculate and sample at the isokinetic rate within 100±10% for the duration of the test. Refer to Appendix B for field data sheets.

Figure 4-4. USEPA Method 5 Sampling Apparatus

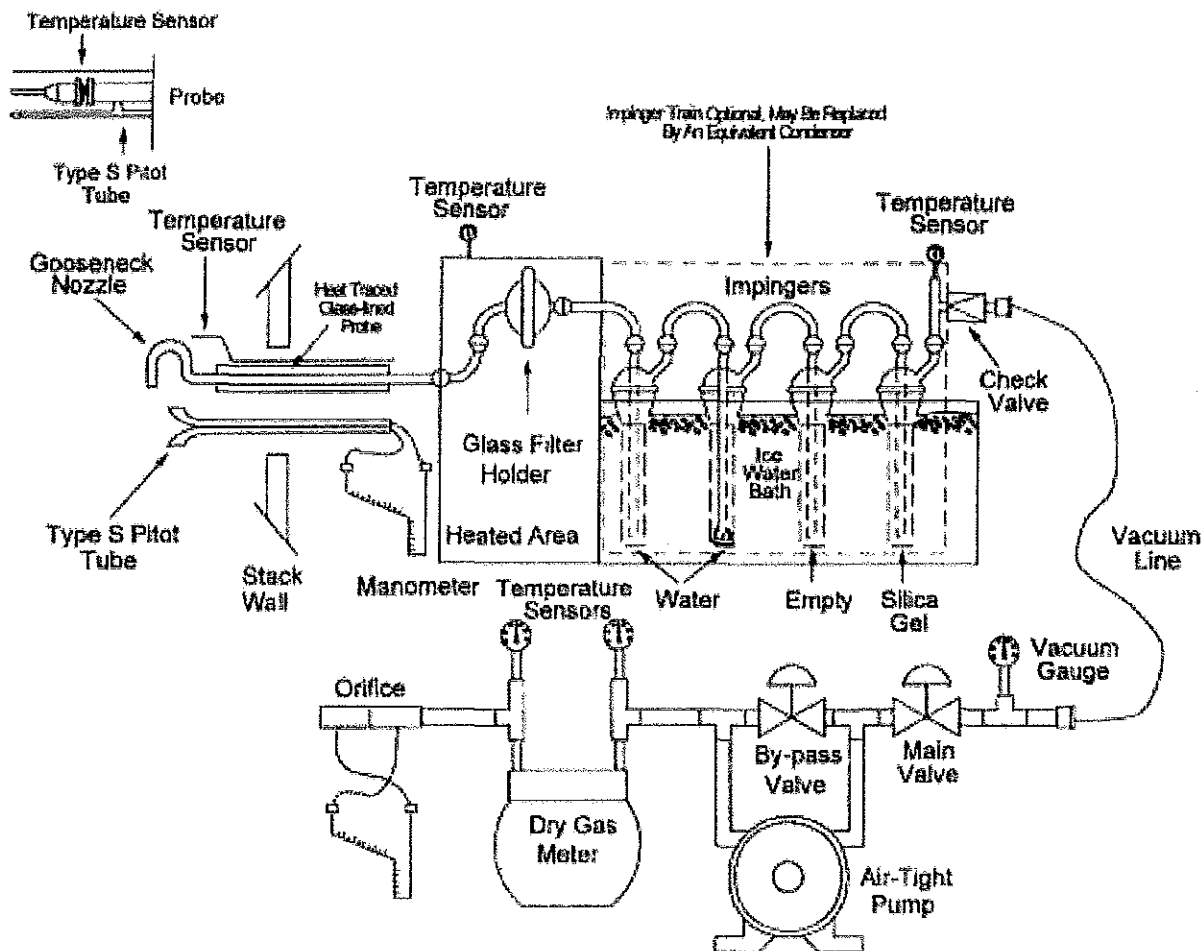

At the conclusion of a test run and post-test leak check, the sampling apparatus was disassembled and the impingers and filter housing were transported to the recovery area.

The filter was recovered from the filter housing and placed in a Petri dish, sealed with Teflon tape, and labeled as "FPM Container 1." The nozzle, probe liner, and the front half of the filter housing were triple rinsed with acetone to collect particulate matter. The acetone rinses were collected in pre-cleaned sample containers, sealed with Teflon tape, and labeled as "FPM Container 2." The weight of liquid collected in each impinger, including the silica gel impinger, was measured using an electronic scale; these weights were used to calculate the moisture content of the sampled flue gas. The contents of the impingers were discarded. Refer to Figure 4-5 for the USEPA Method 5 sample recovery scheme.

The sample containers, including a filter and acetone blank were transported to the laboratory for analysis. The sample analysis followed USEPA Method 5 procedures as summarized in the analytical scheme presented in Figure 4-6. Refer to Appendix C for laboratory data sheets.

Figure 4-5. USEPA Method 5 Sample Recovery Scheme

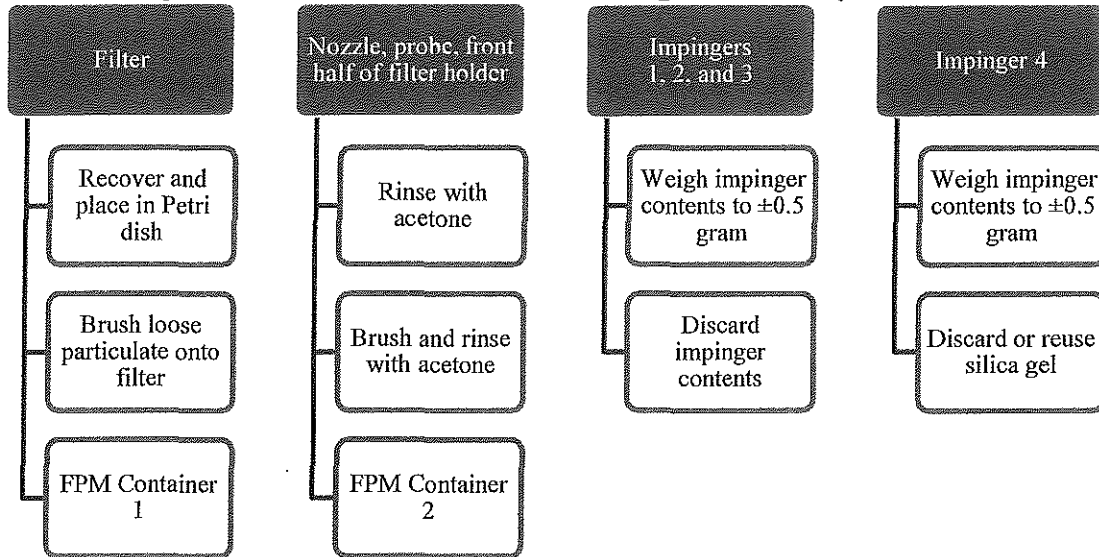
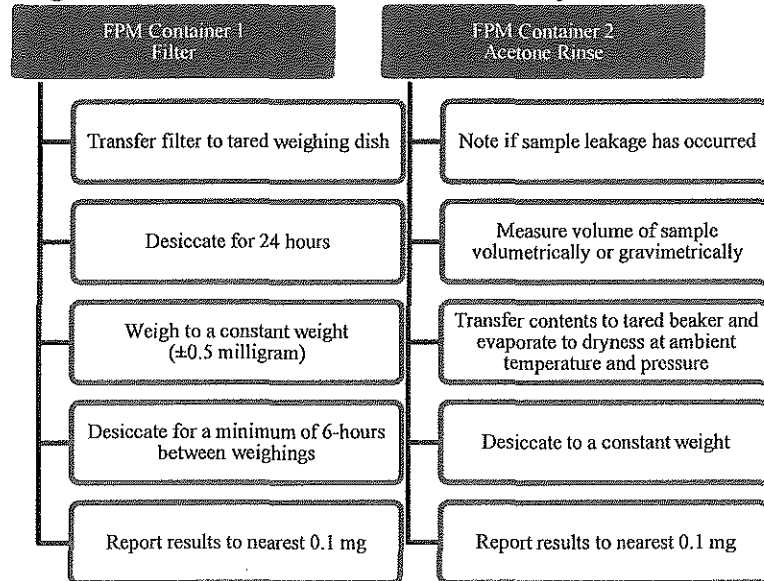

Figure 4-6. USEPA Method 5 Analytical Scheme



4.1.6 Emission Rates (USEPA Method 19)

USEPA Method 19, *Determination of Sulfur Dioxide Removal Efficiency and Particulate Matter, Sulfur Dioxide, and Nitrogen Oxide Emission Rates*, was used to calculate PM emission rates in units of lb/mmBtu. Measured carbon dioxide concentrations and F factors (ratios of combustion gas volumes to heat inputs) were used to calculate emission rates using equation 19-6 from the method. Figure 4-7 presents the equation used to calculate lb/mmBtu emission rate:

Figure 4-7. USEPA Method 19 Equation 19-6

$$E = C_d F_c \frac{100}{\%CO_{2d}}$$

Where:

- E = Pollutant emission rate (lb/mmBtu)
- C_d = Pollutant concentration, dry basis (lb/dscf)
- F_c = Volumes of combustion components per unit of heat content
1,840 scf CO₂/mmBtu for subbituminous coal from 40 CFR 75, Appendix F, Table 1
- %CO_{2d} = Concentration of carbon dioxide on a dry basis (% , dry)

The Unit 1 CEMS utilize the fuel factor provisions in 40 CFR Part 75, Appendix F, Section 3.3.6.5 whereby the worst case fuel factor for any of the fuels combusted in the unit is used to calculate lb/mmBtu emission rates. Refer to Appendix A for sample calculations.

4.1.7 Hydrogen Chloride (USEPA Method 26)

HCl was measured by collecting an integrated sample of the flue gas following the procedures of USEPA Method 26, *Determination of Hydrogen Halide and Halogen Emissions from Stationary Sources*. Triplicate 145-minute test runs were performed at the EUBOILER1 sampling location by sampling flue gas through a heated glass-lined probe, Teflon filter, and into a series of impingers containing absorbing solutions. The filter collects particulate matter and halide salts, and the acidic and alkaline absorbing solutions collect the gaseous hydrogen halides (HCl) and halogens, respectively. Figure 4-8 depicts the USEPA Method 26 sample apparatus.

Figure 4-8. USEPA Method 26 Sample Apparatus

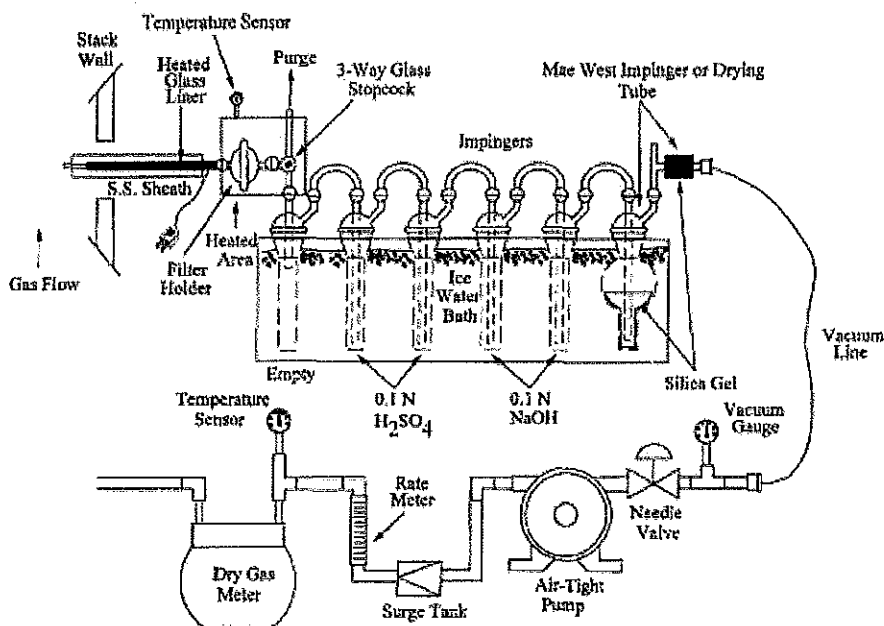

After charging the impingers, assembling the apparatus, and completing a leak check, the sample probe was inserted into the sampling port. Ice was placed around the impingers and upon achieving probe and filter temperatures between 248°F and 273°F, the probe and filter of sampling apparatus was purged with flue gas for a minimum of 5-minutes prior to initiating the test run. During the run, the probe and filter temperatures were maintained and dry gas meter (DGM) volume, temperatures, and sample apparatus vacuum were recorded at 5-minute intervals. After collecting a minimum 240 liter sample volume, sampling was stopped, and a post-test leak check was performed. Refer to Appendix B for the field test data sheets.

The impingers were removed from the sample apparatus and transported to the recovery area. The acidic and alkaline impinger contents were transferred to separate, labeled polyethylene sample containers. While the alkaline impinger contents were submitted to the laboratory they were not analyzed, as halogens were not being assessed as part of the test program. Each impinger was rinsed with deionized water and the rinsate collected in the appropriate sample container. Approximately 0.5 milligrams of sodium thiosulfate was added to the sample storage bottle containing the 0.1 N NaOH impinger catch to assure a complete reaction with the hypohalous acid to form a second chlorine ion. Refer to Figure 4-9 for the Method 26 sample recovery scheme.

Figure 4-9. USEPA Method 26 Sample Recovery Scheme

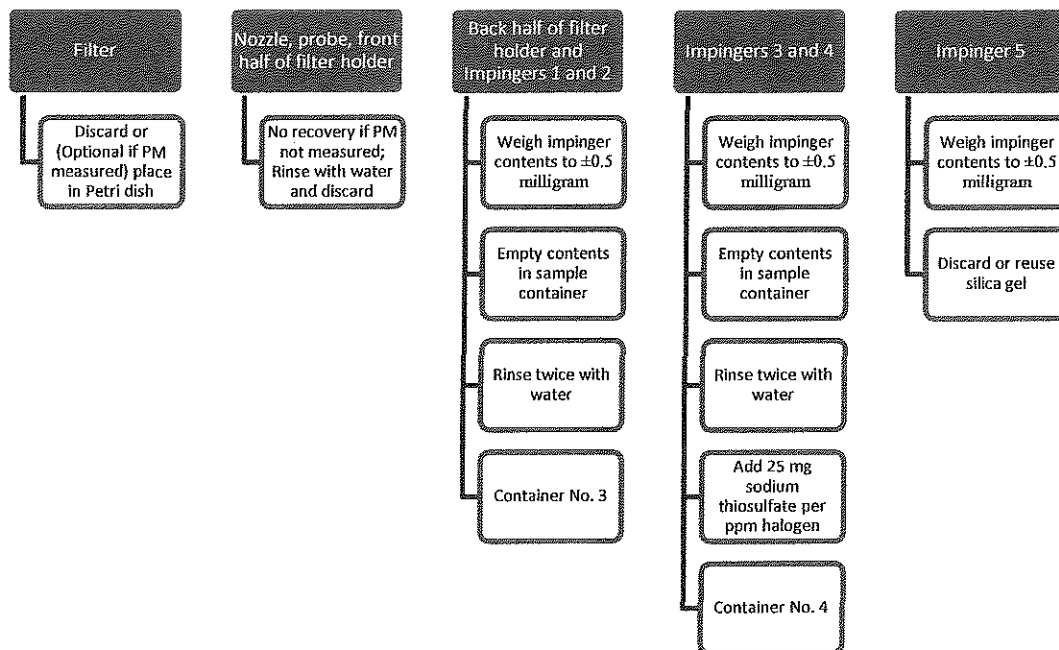

The sample containers, including reagent and water blanks, were transported via courier to the Consumers Energy Laboratory Services facility in Jackson, Michigan under chain-of-custody for hydrogen chloride analysis. The chain of custody was prepared in accordance with ASTM D4840-99(2010) procedures and included the sample date, collection time, identification, and requested analysis. Included with the samples was an HCl performance audit sample with associated documentation. Refer to Figure 4-10 for the Method 26 laboratory analytical scheme and Appendix C for the laboratory data sheets and Section 5.4.2 for further discussion of the audit sample results.

Figure 4-10. USEPA Method 26 Analytical Scheme

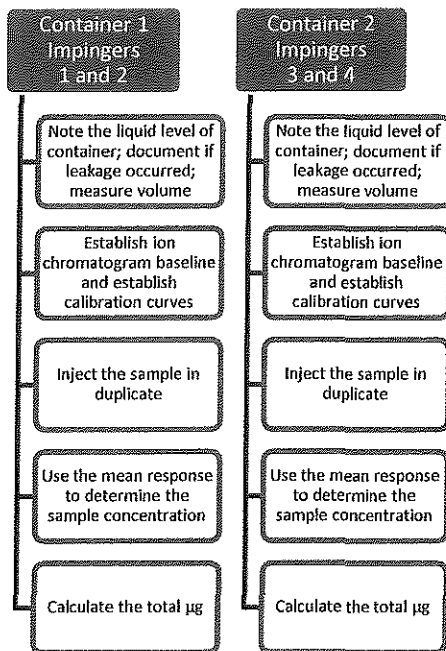

5.0 TEST RESULTS AND DISCUSSION

The test program was performed to satisfy the second quarter 2017 performance test requirements and evaluate compliance with 40 CFR 63, Subpart UUUUU, “National Emission Standards for Hazardous Air Pollutants: Coal- and Oil-Fired Electric Utility Steam Generating Units,” (aka Mercury and Air Toxics Rule [MATS]) as incorporated in the Michigan Department of Environmental Quality (MDEQ) Renewable Operating Permit (ROP) MI-ROP-B2835-2013a. The results of the testing indicate the individual and 3-run average PM and HCl results are in compliance with applicable limits and with the low emitting EGU LEE PM and HCl emission limits for Unit 1 under the MATS regulation.

5.1 VARIATIONS AND UPSET CONDITIONS

No sampling procedure or results affecting boiler operating condition variations were encountered during the test program. The process and control equipment were operating under routine conditions and no upsets were encountered.

5.2 AIR POLLUTION CONTROL DEVICE MAINTENANCE

No significant pollution control device maintenance occurred during the three months prior to the test. Optimization of the air pollution control devices is a continuous process to ensure compliance with regulatory emission limits.

5.3 FIELD QUALITY ASSURANCE / QUALITY CONTROL PROCEDURES

The USEPA reference methods performed state reliable results are obtained by persons equipped with a thorough knowledge of the techniques associated with each method. Factors with the potential to cause measurement errors are minimized by implementing quality control (QC) and assurance (QA) programs into the applicable components of field testing. QA/QC components were included in this test program. Table 5-1 summarizes the primary field quality assurance and quality control activities that were performed. Refer to Appendix E for supporting documentation.

Table 5-1
Quality Control Procedures

QC Specification	Purpose	Procedure	Frequency	Acceptance Criteria
M1: Sampling Location	Evaluate if the sampling location is suitable for sampling	Measure distance from ports to downstream and upstream disturbance	Pre-test	≤ 2 diameters downstream; ≤ 0.5 diameter upstream.
M1: Duct diameter	Verify area of stack is accurately measured	Review as-built drawings and field measurement	Pre-test	Field measurement agreement with as-built drawings
M3A: Calibration gas standards	Ensure accurate calibration standards	Traceability protocol of calibration gases	Pre-test	Calibration gas uncertainty $\leq 2.0\%$
M3A: Calibration Error	Evaluates operation of analyzers	Calibration gases introduced directly into analyzers	Pre-test	$\pm 2\%$ of the calibration span
M3A: System Bias and Analyzer Drift	Evaluates ability of sampling system to delivery stack gas to analyzers	Cal gases introduced at inlet of sampling system and into analyzers	Pre-test and Post-test	$\pm 5\%$ of the analyzer calibration span for bias and $\pm 3\%$ of analyzer calibration span for drift
M3: Single point grab sample	Ensure representative sample collection	Insert probe into stack and purge sample system	Pre-test	Collect sample no closer to the stack walls then 1.0 meter
M5: nozzle diameter measurements	Verify nozzle diameter used to calculate sample rate	Measure inner diameter across three cross-sectional chords	Pre-test	3 measurements agree within ± 0.004 inch
M5: sample rate	Ensure representative sample collection	Calculate isokinetic sample rate	During and post-test	$100 \pm 10\%$ isokinetic rate
M5: sample volume	Ensure sufficient sample volume is collected	Record pre- and post-test dry gas meter volume reading	Post test	≥ 1 dscm minimum; ≥ 2 dscm minimum for LEE
M5: post-test leak check	Evaluate if the sample was affected by system leak	Cap sample train; monitor dry gas meter	Post-test	≤ 0.020 cfm

Table 5-1
Quality Control Procedures

QC Specification	Purpose	Procedure	Frequency	Acceptance Criteria
M5: post-test meter audits	Evaluates accurate measurement equipment for sample volume	DGM pre- and post-test; compare calibration factors (Y and Y _{qa})	Pre-test Post-test	±5 %
M26: Apparatus Temperature	Ensures purge of acid gases in glass probe liner and Teflon filter	Set probe & filter heat controllers to ≥248°F	Verify prior to and during each run	Apparatus temperature must be ≥248°F and ≤273°F
M26: sample rate	Ensure representative sample collection	Calculate rate based on volume collected	During and post-test	Target sample rate is ~2 liters/minute
M26: sample volume	Ensure sufficient sample volume is collected	Record pre- and post-test DGM volume reading	Post test	≥120 liters minimum; ≥240 liters minimum for LEE
M26: post-test leak check	Evaluate if the collected sample was affected by leak	Cap sample train; monitor DGM	Pre-test optional, post-test mandatory	Leak rate ≤2% of the average sample rate

5.3.1 Dry Gas Meter QA/QC Checks

The dry-gas meter calibration checks in comparison to the USEPA tolerance were acceptable. Refer to Appendix E for supporting calibration data.

5.3.2 Thermocouple QA/QC Checks

Thermocouple temperature calibrations were conducted following *Alternative Method 2 Thermocouple Calibration Procedure ALT-011*. ALT-011 describes the inherent accuracy and precision of the thermocouple within ±1.3°F in the range of -32°F and 2500°F and states that a system that performs accurately at one temperature is expected to behave similarly at other temperatures. Therefore, the two-point calibration described in Method 2 may be replaced with a single point calibration procedure that verifies the thermocouple and reference thermometers shall agree to within ±2.0°F, while taking into account the presence of disconnected wire junctions, other loose connections or a potential mis-calibrated temperature display. Thermocouple calibration data is presented with the Dry Gas Meter Calibration Data in Appendix E of this report, and thermocouples met the required calibration criteria.

5.3.3 Oxygen and Carbon Dioxide Analyzer QA/QC Checks

The Method 3A sampling apparatus described in Section 4.1.3 were audited for measurement accuracy and data reliability. The analyzers passed the applicable calibration criteria. Refer to Appendix E for additional calibration data.

5.4 LABORATORY QUALITY ASSURANCE / QUALITY CONTROL PROCEDURES

Laboratory quality assurance and quality control procedures were performed in accordance with USEPA Method 5 and 26 guidelines. Specific QA/QC procedures include evaluation of reagent and filter blanks, the application of blank corrections, duplicate and/or triplicate measurement, and analysis of calibration standards. Refer to Appendix C for the laboratory data sheets.

5.4.1 QA/QC Blanks

Reagent and media blanks were analyzed for the parameters of interest. The results of the blanks are presented in the Table 5-2.

Table 5-2
QA/QC Blanks

Sample Identification	Result	Comment
Method 5 Acetone Field Blank	0.1 mg	Sample volume was 200 milliliters. Acetone blank corrections of ~0.01 mg were applied.
Method 5 Laboratory Filter Blank	0.1 mg	Reporting limit is 0.1 milligrams.
0.1 N H ₂ SO ₄ Reagent Blank	<31.2 µg	Sample volume was 53 milliliters. Blank corrections were not applied.
Water Blank	<31.2 µg	Sample volume was 31 milliliters. Blank corrections were not applied.

RECEIVED

JUL 03 2017

AIR QUALITY DIV.

5.4.2 Audit Samples

A performance audit (PA) sample (if available) for each test method employed is required, unless waived by the administrator for regulatory compliance purposes as described in 40 CFR 63.7(c)(2)(iii). The PA sample consist of blind audit sample(s), as supplied by an accredited audit sample provider (AASP), which are analyzed with the performance test samples in order to provide a measure of test data bias. Based on discussions with the MDEQ, an audit sample shall be conducted once per year on either Boiler 1 or Boiler 2. An audit sample was ordered and analyzed for Boiler 1 during the first quarter 2017 test event. The results of the audit sample analysis were within acceptable limits.

Table 1 - Particulate Matter Results

Facility and Source Information		Units	Run 1	Run 2	Run 3	Average
Customer:			J.H. Campbell			
Source:			EUBOILER1			
Work Order:			27538841			
Date:			5/11/2017	5/11/2017	5/11/2017	
Unit Load:	MW _g		273	274	274	274
Stack Length, L	inches		224.0	224.0	224.0	
Stack Width, W	inches		180.0	180.0	180.0	
Cross-sectional Area of Stack, A	ft ²		280.00	280.00	280.00	
Source Pollutant Test Data		Units	Run 1	Run 2	Run 3	Average
Barometric Pressure, P _{bar}	inches of Hg		29.35	29.35	29.35	29.35
Dry Gas Meter Calibration Factor, Y	dimensionless		1.003	1.003	1.003	1.003
Pitot Tube Coefficient, C _p	dimensionless		0.84	0.84	0.84	0.84
Stack Static Pressure, P _g	inches of H ₂ O		2.50	2.50	2.50	2.50
Nozzle Diameter, D _n	inches		0.277	0.277	0.277	0.277
Run Start Time	hr:mm		7:40	10:29	13:10	
Run Stop Time	hr:mm		9:59	12:47	15:28	
Duration of Sample, θ	minutes		125	125	125	125
Dry Gas Meter Leak Rate, L _p	cfm		0.000	0.000	0.000	0.000
Dry Gas Meter Start Volume	ft ³		306.42	428.78	548.17	427.79
Dry Gas Meter Final Volume	ft ³		428.53	547.90	670.69	549.04
Average Pressure Difference across the Orifice Meter, ΔH	inches of H ₂ O		3.34	3.12	3.30	3.25
Average Dry Gas Meter Temperature, T _m	°F		65.5	73.2	75.8	71.5
Average Square Root Velocity Head, √Δp	√inches H ₂ O		0.9555	0.9182	0.9448	0.9395
Stack Gas Temperature, T _{s(average)}	°F		325.9	332.6	336.1	331.5
Source Moisture Data		Units	Run 1	Run 2	Run 3	Average
Volume of Water Vapor Condensed, V _{wv(std)}	scf		12.5	12.0	12.2	12.2
Volume of Water Vapor Condensed in Silica Gel, V _{wsg(std)}	scf		1.6	1.7	1.8	1.7
Total Volume of Water Vapor Condensed, V _{w(std)}	scf		14.070	13.664	14.013	13.916
Volume of Gas Sample as Measured by the Dry Gas Meter, V _m	dcf		122.110	119.120	122.515	121.248
Volume of Gas Sample Measured by the Dry Gas Meter corrected to STP, V _{m(std)}	dscf		121.684	116.927	119.725	119.446
Volume of Gas Sample Measured by the Dry Gas Meter corrected to STP, V _{m(std)}	dscfm		3.446	3.311	3.391	3.38
Moisture Content of Stack Gas, B _{wv}	% H ₂ O		10.36	10.46	10.48	10.44
Gas Analysis Data		Units	Run 1	Run 2	Run 3	Average
Carbon Dioxide, %CO ₂	%, dry		10.7	11.8	13.3	11.9
Oxygen, %O ₂	%, dry		8.1	7.7	6.2	7.3
Nitrogen, %N	%, dry		81.21	80.45	80.53	80.73
Dry Molecular Weight, M _d	lb/lb-mole		30.03	30.20	30.37	30.20
Wet Molecular Weight, M _w	lb/lb-mole		28.79	28.92	29.08	28.93
Percent Excess Air, %EA	%		60.80	57.30	40.96	53.02
Fuel F-Factor, F _c	dimensionless		1.197	1.114	1.108	1.140
Fuel F-Factor, F _c	scf/mmBtu		1,840	1,840	1,840	1,840
Gas Volumetric Flow Rate Data		Units	Run 1	Run 2	Run 3	Average
Average Stack Gas Velocity, v _s	ft/s		66.0	63.5	65.3	64.9
Stack Gas Volumetric Flow Rate, Q	acfm		1,108,297	1,067,085	1,097,501	1,090,961
Stack Gas Standard Volumetric Flow Rate, Q _s	scfm		735,008	701,641	718,522	718,390
Stack Gas Dry Standard Volumetric Flow Rate, Q _{sd}	dscfm		658,831	628,227	643,236	643,432
Percent of Isokinetic Sampling, I	%		98.9	99.7	99.7	99.4
Gas Concentrations and Emission Rates		Units	Run 1	Run 2	Run 3	Average
Mass of Filterable PM Collected, m _f	mg		11.29	9.49	12.09	10.96
Filterable PM Concentration, c _f	gr/dscf		0.00143	0.00125	0.00156	0.00141
Filterable PM Concentration at Stack Conditions, c _{f@stack conditions}	mg/wacm		1.948	1.687	2.090	1.908
Filterable PM Concentration, C _f [Actual Conditions, Wet Basis]	lb/1,000 lbs		0.002	0.002	0.003	0.002
Filterable PM Concentration, C _{f50} [Actual Conditions, Wet Basis]	lb/1,000 lbs @ 50% EA		0.003	0.002	0.002	0.002
Filterable PM Mass Emission Rate, E	lb/hr		8.07	6.73	8.58	7.79
Filterable PM, lb/mmBtu, E	lb/mmBtu		0.0035	0.0028	0.0031	0.0031
Filterable PM, tpy [Assumes 8,760 Hrs/Yr Operation]	tpy		35.34	29.48	37.57	34.13

Table 2 - HCl Results

Facility and Source Information				
Facility:	J.H. Campbell			
Source:	Unit 1		Unit Load:	High
Work Order:	27538841			
Date:	5/11/2017	5/11/2017	5/11/2017	
Run Number:	Run 1	Run 2	Run 3	
Run Start Time:	8:21	11:05	13:45	
Run Stop Time:	10:21	13:05	15:45	
Dry Gas Meter Calibration Factor, Y, dimensionless:	1.000	1.000	1.000	
Stack Length, L, inches:	224.0	224.0	224.0	
Stack Width, W, inches:	180.0	180.0	180.0	
Stack Area, A, ft ² :	280.00	280.00	280.00	
Unit Operating Conditions During Test Period				
	Run 1	Run 2	Run 3	Average
Heat Input Rate, mmBtu/hr:	2,616.3	2,622.4	2,690.4	2,643.0
Sub-Bituminous Coal F-Factor, F _{co} , scf CO ₂ /mmBtu:	1,840	1,840	1,840	1,840
Unit Load, MW _g :	273	274	274	274
Source Test Data				
	Run 1	Run 2	Run 3	Average
Barometric Pressure, P _{bar} , in Hg:	29.35	29.39	29.36	29.37
Stack Static Pressure, P _g , in H ₂ O:	2.5	2.5	2.5	2.5
Duration of Sample, θ, minutes:	120	120	120	120
Meter Leak Rate, ft ³ /min:	0.000	0.000	0.000	0.000
Meter Start Volume, ft ³ :	0	0	0	
Meter Final Volume, ft ³ :	8.80	9.04	8.89	
Sampling Rate, l/min:	2.077	2.134	2.098	2.103
Average Meter Orifice Pressure, in. H ₂ O:	2.244	2.268	2.200	2.237
Average Meter Temperature, T _m , °F:	60.1	64.4	66.5	63.7
Sample Volume Data				
	Run 1	Run 2	Run 3	Average
Liquid Volume Collected, milliliters:	19.3	19.7	23.1	20.7
Liquid Volume Collected, grams:	1.8	3.4	1.9	2.4
Water Vapor Volume at STP, V _{w(Std)} , scf:	0.991	1.086	1.175	1.084
Meter Volume, V _m , dcf:	8.803	9.042	8.891	8.912
Meter Volume, V _{m(Std)} , dscf:	8.812	8.990	8.794	8.865
Meter Volume, V _m , dl:	249.28	256.05	251.77	252.37
Meter Volume, V _{m(Std)} , dsl:	249.52	254.57	249.01	251.03
Meter Volume, V _{m(Std)} , dscm:	0.250	0.255	0.249	0.251
Total Gas Sampled, scf:	9.803	10.076	9.969	9.949
Stack Gas Moisture, %:	10.11	10.78	11.78	10.89
Gas Analysis Data				
	Run 1	Run 2	Run 3	Average
Carbon Dioxide, % dry:	10.7	11.8	13.3	11.9
Oxygen, % dry:	8.1	7.7	6.2	7.3
Nitrogen, % dry:	81.2	80.4	80.5	80.7
Dry Molecular Weight, M _d , lb/lb-mole:	30.035	30.201	30.374	30.203
Molecular Weight, at Stack Condition, M _s , lb/lb-mole:	28.818	28.886	28.915	28.873
Calculated Fuel Factor, F _{co} , dimensionless:	1.196	1.113	1.108	1.139
Percent Excess Air, %EA:	60.85	57.35	40.98	53.06
Acid Gas Calculations ¹				
	Run 1	Run 2	Run 3	Average
Hydrogen Chloride (HCl) Molecular Weight:	36.46	36.46	36.46	
HCl Mass, mg:	<0.0312	<0.0312	<0.0312	<0.0312
HCl Concentration, mg/dscm:	<0.1250	<0.1225	<0.1253	<0.1243
HCl Concentration, mg/dscf:	<0.0035	<0.0035	<0.0035	<0.0035
HCl Concentration, ppmv:	<0.0825	<0.0808	<0.0826	<0.0820
HCl Conversion Factor, ppm to lb/scf:	9.43E-08	9.43E-08	9.43E-08	
HCl Emission Rate, lb/mmBtu:	<0.0001	<0.0001	<0.0001	<0.0001