



COMPLIANCE TEST REPORT

for

QUARTERLY HYDROGEN CHLORIDE (HCL) EMISSIONS

EU-BOILER1-BR

(SRN: B2796)

3rd Quarter 2022

**Belle River Power Plant
China Twp, Michigan**

September 7, 2022

**Prepared By:
Environmental Management & Safety
Ecology, Monitoring, and Remediation Group
DTE Corporate Services, LLC
7940 Livernois Ave, G4-S
Detroit, MI 48210**



CONTENTS

<u>Section</u>	<u>Page</u>
1.0 INTRODUCTION	1
2.0 SOURCE DESCRIPTION	1
3.0 SAMPLING AND ANALYTICAL PROCEDURES	2
3.1 MOISTURE DETERMINATION (USEPA METHOD 4)	2
3.1.1 Sampling Method	2
3.2 HYDROGEN CHLORIDE (USEPA METHOD 26A).....	2
3.2.1 HCl Sampling Method	2
3.2.2 Quality Control and Assurance	3
3.2.3 Data Reduction	3
4.0 OPERATING PARAMETERS.....	3
5.0 DISCUSSION OF RESULTS	4
6.0 CERTIFICATION STATEMENT	5

RESULTS TABLES

Table No. 1: HCl Emissions Testing Summary – EU-BOILER1-BR

FIGURES

- 1 Sampling Location – EU-BOILER1-BR
- 2 USEPA Method 26A Sampling Train

APPENDICES

- A Test Plan and Approval Letter
- B Field Sampling Data
- C Process Operational Data
- D Example Calculations
- E Analytical Data
- F Calibration Data

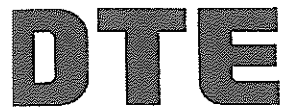

EXECUTIVE SUMMARY

DTE Energy's Environmental Management and Safety (EM&S) Ecology, Monitoring, and Remediation Group performed 3rd Quarter – 2022 Hydrogen Chloride (HCl) emissions testing on the exhaust of EU-BOILER1-BR at the Belle River Power Plant, located in China Township, Michigan. Testing is required by 40 CFR Part 63, Subpart UUUUU (Mercury and Air Toxics Standards - MATS) to document quarterly HCl stack emissions. Testing was conducted on September 7, 2022.

A summary of the emission test results is shown below:

Emissions Testing Summary Belle River Power Plant EU-BOILER1-BR

Source	Date	Load (GMW)	HCl (lbs/MmBtu) ⁽¹⁾
EU-BOILER1-BR	9-7-22	640	0.0004

(1) MATS Limit 0.0020 lbs/MMBtu

1.0 INTRODUCTION

DTE Energy's Environmental Management and Safety (EM&S) Ecology, Monitoring, and Remediation Group performed 3rd Quarter – 2022 Hydrogen Chloride (HCl) emissions testing on the exhaust of EU-BOILER1-BR at the Belle River Power Plant, located in China Township, Michigan. The testing was required by the 40 CFR Part 63, Subpart UUUUU (Mercury and Air Toxics Standards - MATS) to document quarterly HCl stack emissions. The testing was conducted on September 7, 2022.

The fieldwork was performed in accordance with EPA Reference Methods and DTE Energy Intent to Test¹, which was approved in a letter by Ms. Regina Angellotti from the Michigan Department of Environmental Quality (MDEQ), dated November 10, 2020². The following DTE Energy personnel participated in the testing program: Mr. Mark Westerberg, Senior Environmental Specialist, and Mr. Fred Meinecke, Environmental Specialist. Mr. Westerberg was the project leader. Mr. Jason Roggenbuck, Senior Environmental Engineer at the plant, provided process coordination for the testing program.

2.0 SOURCE DESCRIPTION

The Belle River Power Plant (BRPP) located at 4505 King Road in China, Michigan, employs the use of two (2) Babcock and Wilcox coal-fired boilers (Unit 1 & 2) each capable of producing 4,550,000 pounds per hour of steam. Each unit has a Siemens Power Corporation boiler generator with a nominally rated capability of 635 (EU-BOILER1-BR) and 645 (EU-BOILER2-BR) gross megawatts (GMW). See Figure 1 for a diagram of the units' sampling locations and stack dimensions.

The air pollution control equipment consists of Wheelabrator Frye cold gas electrostatic precipitators on each unit that have design collection efficiencies greater than 99%. Each exhaust Stack is 665 feet tall with an internal diameter of 25.5 feet.

Each boiler is equipped with a Dry Sorbent Injection (DSI) and Activated Carbon Injection (ACI) air quality control system. The DSI system is used to control acid gas, PM, PM10, PM2.5, and NOx emissions from each unit.

Testing was performed on EU-BOILER1-BR while operating at normal load conditions, per Subpart UUUUU.

¹ Test Plan, Submitted October 18, 2021. (Attached-Appendix A)

² Approval Letter, dated November 10, 2020. (Attached-Appendix A)

3.0 SAMPLING AND ANALYTICAL PROCEDURES

DTE Energy obtained emissions measurements in accordance with procedures specified in the USEPA *Standards of Performance for New Stationary Sources* or listed as an approved "Other Test Method". The sampling and analytical methods used in the testing program are indicated in the table below:

Sampling Method	Parameter	Analysis
USEPA Method 4	Moisture Content	Field data analysis and reduction
USEPA Method 26A	Hydrogen Chloride	Ion Chromatography
USEPA Method 19	Emission Rate Calculations	Stoichiometric Calculations

3.1 MOISTURE DETERMINATION (USEPA METHOD 4)

3.1.1 Sampling Method

Determination of the moisture content of the exhaust gas was performed using the method described in USEPA Method 4, "Determination of Moisture Content in Stack Gases". The exhaust gas condensate was collected in glass impingers and the percentage of moisture was derived from calculations outlined in USEPA Method 4 as a component of the HCl sampling train.

3.2 HYDROGEN CHLORIDE (USEPA Method 26A)

3.2.1 HCl Sampling Method

USEPA Method 26A, "Determination of Hydrogen Halide and Halogen Emissions" was used to measure the Hydrochloric Acid (HCl) emissions (see Figure 2 for a schematic of the sampling train). Method 26A uses impingers containing 0.1N H₂SO₄ to capture the HCl. Triplicate, 60-minute test runs were conducted. Method 26A sampling was performed as a single point sample per Method 26 procedures.

The Method 26A stack sampling system (Figure 2) consisted of the following:

- (1) Heated glass-lined probe (Maintained 248 °F > T > 273 °F)
- (2) Heated 3" glass filter holder with a PTFE filter (maintained at a temperature of 248 °F > T > 273 °F)
- (3) Set of impingers for the collection HCl and condensate for moisture determination (Impingers containing 0.1N H₂SO₄)
- (4) Length of sample line

- (5) Environmental Supply[®] control case equipped with a pump, dry gas meter, and calibrated orifice.

After completion of each run, a leak test was conducted. All the impingers were measured for moisture gain. The contents of impingers 1 and 2 were collected in a designated sample container. Impingers 1 and 2, the back half of the filter holder, the Z-fitting connecting the filter holder to the first impinger, and the U-tube between the first and second impingers were then rinsed with DI water and collected in the same sample container. Each container was labeled with the test number, test location, test date, and the level of liquid marked on the outside of the container. Immediately after recovery, the sample containers were placed in a cooler for storage.

Collected field blanks consisted of a 0.1N H₂SO₄ solution blank. 200ml of 0.1N H₂SO₄ was collected and diluted with DI water, from the same bottle used in sample recovery, to the liquid level of the three test runs. The blank was collected and analyzed following the same procedures used to recover and analyze the field samples.

Analysis of the Method 26A samples and blanks were conducted by Enthalpy Analytical. All analysis followed the procedures listed in USEPA Method 26A. A complete laboratory report is in Appendix E.

Field data sheets for the Method 26A sampling are in Appendix B.

3.2.2 Quality Control and Assurance

All sampling and analytical equipment was calibrated per the guidelines referenced in EPA Method 5 and 26A.

3.2.3 Data Reduction

HCl emissions data collected during the testing were calculated and reported as parts per million (ppm) and pounds per million Btu (lb/MMBtu). CO₂ data from the DAHS was used in conjunction with Method 19 to calculate emissions in lb/MMbtu for comparison to the emission limits.

4.0 OPERATING PARAMETERS

The test program included the collection of boiler load and stack emissions CEMs data during each test run. Parameters recorded included gross Megawatts (GMW), CO₂ (%), NO_x (ppm), SO₂ (ppm), and opacity (%). Additionally, dry sorbent injection rates (DSI) and activated carbon injection rates (ACI), in pounds per hour (lb/hr), are reported. Operational Data collected during the testing is presented in Appendix C.

HCl emissions testing was performed at normal operating load and representative of site specific normal operating conditions according to 40 CFR part 63.10007. 100 percent low sulfur western subbituminous coal fueled the boiler during the testing.

5.0 DISCUSSION OF RESULTS

Table 1 presents the HCl emission testing results from EU-BOILER1-BR. HCl emissions are presented in parts per million on a wet basis (ppm_w) and pounds per million BTU (lbs/MMBtu). The EU-BOILER1-BR HCl emissions during the testing demonstrated an average HCl concentration of 0.27 ppm and 0.0004 lb/MMBtu. The average EU-BOILER1-BR HCl emissions were within the Subpart UUUUU limit of 0.0020 lb/MMBtu.

The auxiliary test data presented in the results table for each test includes the unit load in gross megawatts (GMW), DSI injection rate (lb/hr), ACl injection rate (lb/hr), and CO₂ concentration (%_{wet}).

RECEIVED

OCT 18 2022

AIR QUALITY DIVISION

6.0 CERTIFICATION STATEMENT

"I certify that I believe the information provided in this document is true, accurate, and complete. Results of testing are based on the good faith application of sound professional judgment, using techniques, factors, or standards approved by the Local, State, or Federal Governing body, or generally accepted in the trade."

Mark D. Westerberg

Mr. Mark D. Westerberg, QSTI

This report prepared by: *Mark D. Westerberg*

Mr. Mark D. Westerberg, QSTI
Sr. Environmental Specialist, Ecology, Monitoring, and Remediation
Environmental Management and Safety
DTE Energy Corporate Services, LLC

This report reviewed by: _____

Thomas Snyder

Mr. Thomas Snyder, QSTI
Sr. Environmental Specialist, Ecology, Monitoring, and Remediation
Environmental Management and Safety
DTE Energy Corporate Services, LLC

DTE

RESULTS TABLES



TABLE NO. 1
HYDROGEN CHLORIDE EMISSIONS TESTING RESULTS
Belle River Power Plant - Unit 1
September 7, 2022

Test	Test Date	Test Time	Unit Load (GMW)	DSI Injection Rate (lb/hr)	ACI Injection Rate (lb/hr)	CO ₂ Concentration (%)	HCl Concentration (ppmv)	HCl Emissions (lbs/MMBtu) ⁽¹⁾
HCl-1	7-Sep-22	6:24-7:24	640	7	265	11.1	0.28	0.0005
HCl-2		7:36-8:36	640	4	273	11.0	0.29	0.0005
HCl-3		8:50-9:50	<u>641</u>	<u>21</u>	<u>263</u>	<u>11.0</u>	<u>0.24</u>	<u>0.0004</u>
<i>Average:</i>			<i>640</i>	<i>11</i>	<i>267</i>	<i>11.0</i>	<i>0.27</i>	<i>0.0004</i>

(1) MATS Limit = 0.0020 lb/MMBtu

DTE

FIGURES

Figure 1 – Sampling Location
Belle River Power Plant – Unit 1
September 7, 2022

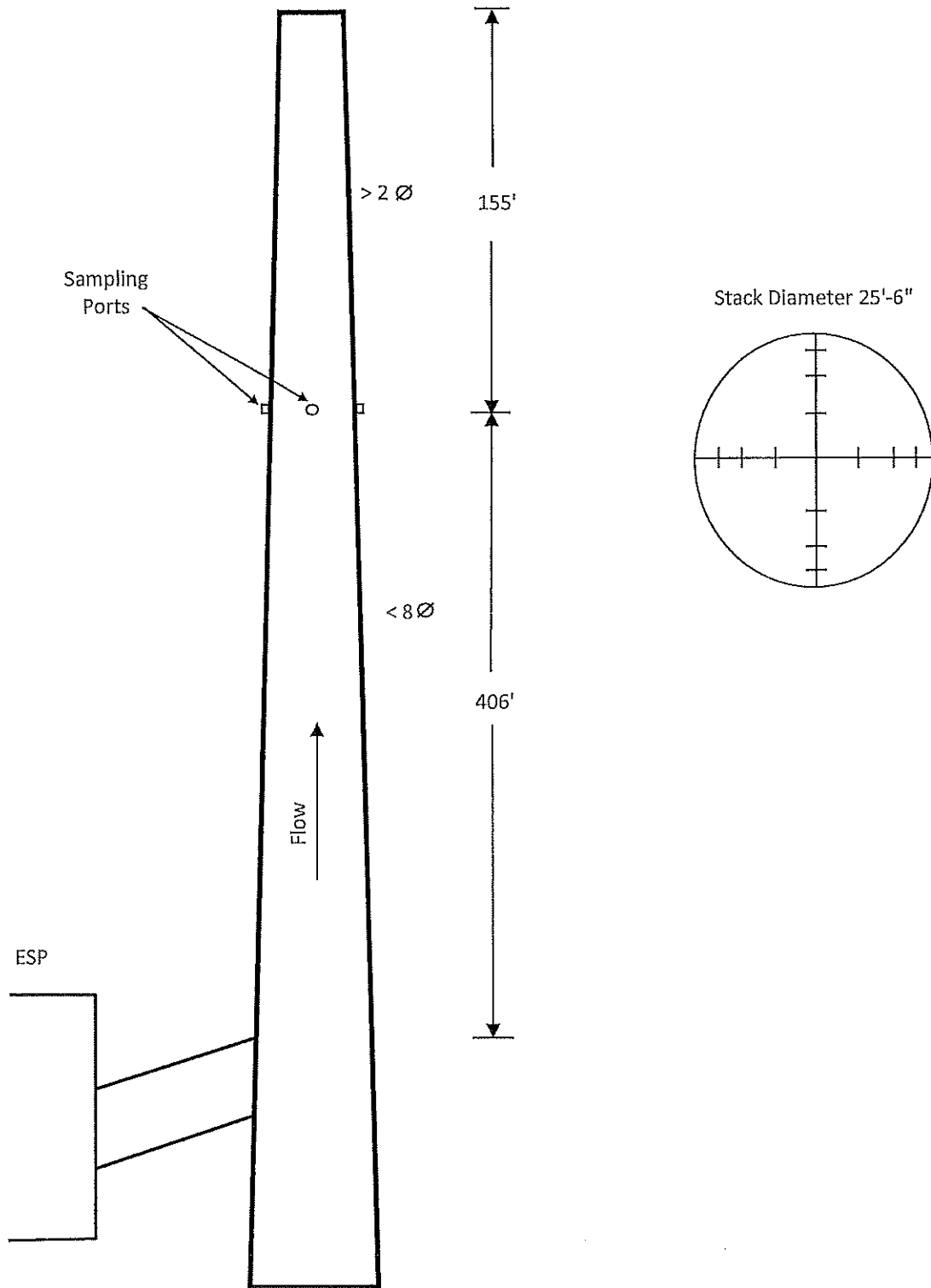
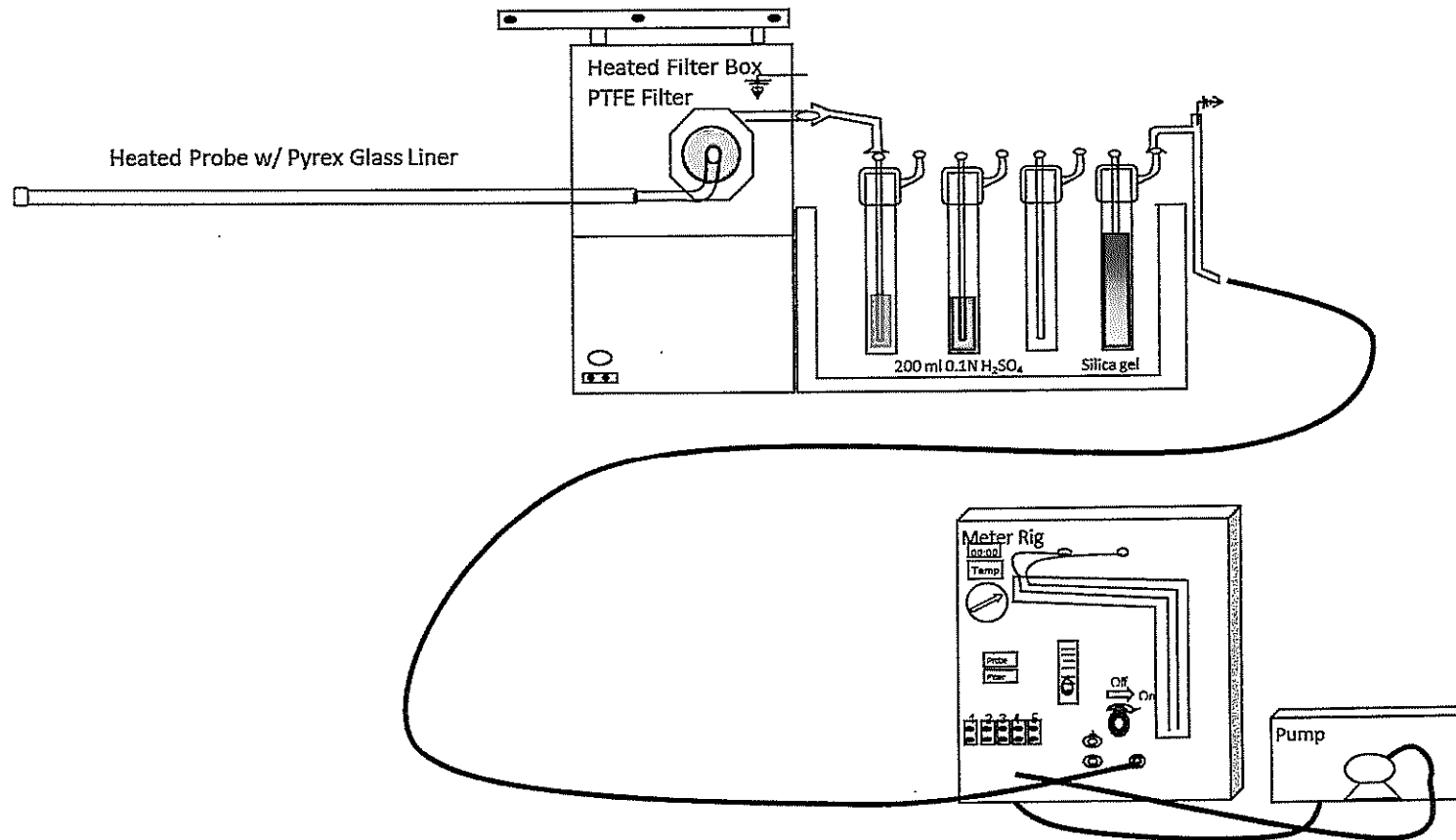

Figure 2 – Method 26A-Modified
Belle River Power Plant
September 7, 2022



DTE

APPENDIX A

**TEST PLAN AND
APPROVAL LETTER**