



# **COMPLIANCE TEST REPORT**

for

## **QUARTERLY HYDROGEN CHLORIDE (HCL) EMISSIONS**

**UNIT 7**

**(SRN: B2796)**

**2nd Quarter 2018**

**St. Clair Power Plant  
East China, Michigan**

**May 18, 2018**

**RECEIVED**  
JUN 28 2018  
AIR QUALITY DIVISION

**Prepared By:  
Environmental Management & Resources  
Environmental Field Services Group  
DTE Corporate Services, LLC  
7940 Livernois H-136  
Detroit, MI 48210**



**EXECUTIVE SUMMARY**

DTE Energy’s Environmental Management and Resources (EM&R) Field Services Group performed the 2nd Quarter – 2018 Hydrogen Chloride (HCl) emissions test on the exhaust of Unit 7 at the St. Clair Power Plant, located in East China, Michigan. The testing was required by the 40 CFR Part 63, Subpart UUUUU (Mercury and Air Toxics Standards - MATS) to document quarterly HCl stack emissions. The testing was conducted on May 18, 2018.

A summary of the emission test results is shown below:

**Emissions Testing Summary  
St. Clair Power Plant  
Unit 7**

<b>Source</b>	<b>Date</b>	<b>Load (GMW)</b>	<b>HCl (lbs/MmBtu)<sup>(1)</sup></b>
<b>Unit 7</b>	5-18-18	298.0	<0.0003

(1) MATS Limit 0.002 lbs/MMBtu



## 1.0 INTRODUCTION

DTE Energy's Environmental Management and Resources (EM&R) Field Services Group performed the 2nd Quarter – 2018 Hydrogen Chloride (HCl) emissions test on the exhaust of Unit 7 at the St. Clair Power Plant, located in East China, Michigan. The testing was required by the 40 CFR Part 63, Subpart UUUUU (Mercury and Air Toxics Standards - MATS) to document quarterly HCl stack emissions. The testing was conducted on May 18, 2018.

Testing was performed pursuant to USEPA Method 26A (Modified).

The fieldwork was performed in accordance with EPA Reference Methods and DTE Energy Intent to Test<sup>1</sup>. Emissions testing was performed utilizing Method 26A (modified as a single point sample) due equipment availability limitations which did not allow for FTIR analysis. The following DTE Energy personnel participated in the testing program: Mr. Mark Grigereit, Principal Engineer, Mr. Thom Snyder, Environmental Specialist and Mr. Fred Meinecke, Senior Environmental Technician. Mr. Snyder was the project leader. Mr. Joe Neruda, Senior Environmental Specialist at the plant provided process coordination for the testing program.

## 2.0 SOURCE DESCRIPTION

The St Clair Power Plant (SCPP) located at 4901 Pointe Drive in East China, Michigan, employs the use of five (5) coal-fired boilers (Units 1-3, 6, and 7). Units 1-3 each have Babcock and Wilcox boilers capable of producing 1,070,000 pounds per hour of steam. Unit 1 is equipped with a General Electric turbine generator nominally rated capability of 167 megawatts (MW). Units 2 and 3 have Allis Chalmers turbine generators each with a nominally rated capability of 170 MW. Full load capability for Units 1-3, while firing coal only, are 135 MW and 150 MW while over-firing with oil.

Units 6 and 7 have Combustion Engineering boilers capable of producing 2,100,000 and 3,580,000 pounds of steam per hour respectively. The turbine generators on each unit were manufactured by Westinghouse and have a nominally rated capability of 325 and 500 megawatts respectively. Full load capability for Units 6 and 7 while firing coal only is approximately 315 MW and 470 MW respectively.

The air pollution control equipment on Units 1-3 consists of Wheelabrator Frye electrostatic precipitators on each unit that have design collection efficiencies of 99.6%. Each exhaust stack is 599 feet tall with an internal diameter of 13.3 feet. The air pollution control equipment on Unit 6 consists of Research Corporation electrostatic

---

<sup>1</sup> MDEQ, Test Plan, Submitted October 23, 2017. (Attached-Appendix A)



Each exhaust stack is 599 feet tall with an internal diameter of 13.3 feet. The air pollution control equipment on Unit 6 consists of Research Corporation electrostatic precipitators that have design collection efficiencies of 99.6%. The exhaust stack is 425 feet tall with an internal diameter of 19.0 feet. The air pollution control equipment on Unit 7 consists of an American Standard electrostatic precipitator that has design collection efficiency of 99.6%. The exhaust stack is 600 feet tall with an internal diameter of 16.0 feet

Each boiler is equipped with a Dry Sorbent Injection (DSI) and Activated Carbon Injection (ACI) air quality control system. The DSI system is used to control acid gas, PM, PM10, PM2.5, and NOx emissions from each unit. Trona is received at the plant where inline mills further refine the Trona. The ACI system is used to control Mercury emissions from each unit.

Testing was performed on Unit 7 while operating at normal load conditions, per Subpart UUUUU.

### 3.0 SAMPLING AND ANALYTICAL PROCEDURES

DTE Energy obtained emissions measurements in accordance with procedures specified in the USEPA *Standards of Performance for New Stationary Sources* or listed as an approved "Other Test Method". The sampling and analytical methods used in the testing program are indicated in the table below:

Sampling Method	Parameter	Analysis
USEPA Method 3A	Oxygen & CO <sub>2</sub>	Instrumental Analyzer Method
USEPA Method 4	Moisture Content	Field data analysis and reduction
USEPA Method 26a	Hydrogen Chloride	Ion Chromatography
USEPA Method 19	Emission Rate Calculations	Stoichiometric Calculations



### **3.1 OXYGEN AND CARBON DIOXIDE (USEPA Method 3A)**

#### ***3.1.1 Sampling Method***

Stack gas oxygen (O<sub>2</sub>) and carbon dioxide (CO<sub>2</sub>) emissions were evaluated using USEPA Method 3A, "Gas Analysis for Carbon Dioxide, Oxygen, Excess Air, and Dry Molecular Weight (Instrumental Analyzer Method)". The O<sub>2</sub> / CO<sub>2</sub> analyzers utilize paramagnetic sensors.

#### ***3.1.2 O<sub>2</sub> / CO<sub>2</sub> Sampling Train***

The Method 3A sampling system consisted of continuously collecting a gas sample from the exhaust of the Method 5 sampling system. The samples were drawn through a PTFE line into a Servomex™ O<sub>2</sub>/CO<sub>2</sub> gas analyzer.

#### ***3.1.3 Sampling Train Calibration***

The O<sub>2</sub> / CO<sub>2</sub> analyzer was calibrated per procedures outlined in USEPA Method 7E. Zero, span, and mid-range calibration gases were introduced directly into the analyzer to verify the instruments linearity. The O<sub>2</sub>/CO<sub>2</sub> concentrations are recorded on the field data sheets.

### **3.2 MOISTURE DETERMINATION (USEPA Method 4)**

#### ***3.2.1 Sampling Method***

Determination of the moisture content of the exhaust gas was performed using the method described in USEPA Method 4, "Determination of Moisture Content in Stack Gases". The exhaust gas condensate was collected in glass impingers and the percentage of moisture was derived from calculations outlined in USEPA Method 4.

### **3.3 HYDROGEN CHLORIDE (USEPA Method 26A)**

#### ***3.3.1 HCl Sampling Method***

USEPA Method 26A, "Determination of Hydrogen Halide and Halogen Emissions" (Method 26A) was used to measure the Hydrochloric Acid (HCl) emissions (see Figure 2 for a schematic of the sampling train). Method 26A uses impingers containing 0.1N H<sub>2</sub>SO<sub>4</sub> to capture the HCl. Triplicate, 60-minute test runs were conducted. The Method 26A sampling was performed as a single point sample per Method 26 procedures.

The Method 26A stack sampling system (Figure 2) consisted of the following:

- (1) Heated glass-lined probe (Maintained >250 °F)



- (2) Heated 3" glass filter holder with a PTFE filter (maintained at a temperature of >250 °F)
- (3) Set of impingers for the collection HCl and condensate for moisture determination (Impingers containing 0.1N H<sub>2</sub>SO<sub>4</sub>)
- (4) Length of sample line
- (5) Environmental Supply<sup>®</sup> control case equipped with a pump, dry gas meter, and calibrated orifice.

All sampling was conducted at a single point per Method 26.

After completion of each run, a leak test was conducted. All the impingers were measured for moisture gain. Impingers 1, 2 and 3 were rinsed with water and their contents and associated rinses were collected in a pre-cleaned sample container. The containers were labeled with the test number, test location, test date, and the level of liquid marked on the outside of the container. Immediately after recovery, the sample containers were placed in a cooler for storage.

Collected field blanks consisted of a 0.1N H<sub>2</sub>SO<sub>4</sub> solution blank. 200ml of 0.1N H<sub>2</sub>SO<sub>4</sub> was collected and diluted with DI water, from the same bottle used in sample recovery, to the liquid level of the three test runs. The blank was collected and analyzed following the same procedures used to recover and analyze the field samples.

Analysis of the Method 26A samples and blanks were conducted by Maxxaam Analytics. All analysis followed the procedures listed in USEPA Method 26A. A complete laboratory report is in Appendix E.

Field data sheets for the Method 26A sampling are in Appendix B.

### **3.3.2 Quality Control and Assurance**

All sampling and analytical equipment was calibrated per the guidelines referenced in EPA Method 5 and 26A.

### **3.3.3 Data Reduction**

The HCl emissions data collected during the testing were calculated and reported as parts per million (ppm) and pounds per million Btu (lb/MMBtu).

Analysis of the Method 26A samples and blanks were conducted by Maxxaam Analytics. All analysis followed the procedures listed in USEPA Method 26A. A complete laboratory report is in Appendix E.

Field data sheets for the Method 26A sampling are in Appendix B.



#### 4.0 OPERATING PARAMETERS

The test program included the collection of boiler load and stack emissions CEMs data during each test run. Parameters recorded included gross Megawatts (GMW) and CEMs data (SO<sub>2</sub>, NO<sub>x</sub>, CO<sub>2</sub>, and opacity). Additionally, dry sorbent injection rates (DSI) and activated carbon injection rates (ACI), in pounds per hour (lb/hr), are reported. Operational Data collected during the testing is presented in Appendix C.

During each day of emissions sampling, a representative coal sample was collected from the unit and analyzed for ultimate and proximate analysis, including % Sulfur, % Ash, and heat content. The results of the coal analysis were used to calculate an Fc value for each day of testing and used in the lb/MMBtu calculations. Results of the fuel analysis can be referred to in Appendix E.

#### 5.0 DISCUSSION OF RESULTS

Table 1 presents the HCl emission testing results from Unit 7. HCl emissions are presented in parts per million on a wet basis (ppm<sub>w</sub>) and pounds per million BTU (lbs/MMBtu). The Unit 7 HCl emissions during the testing demonstrated an average concentration for HCl of <0.19 ppm. The average Unit 7 HCl emissions were below the Subpart UUUUU limit of 0.002 lb/MMBtu.

The auxiliary test data presented in the results table for each test includes the unit load in gross megawatts (GMW), DSI injection rate (lb/hr), ACI injection rate (lb/hr), and CO<sub>2</sub> concentration (%<sub>wet</sub>).



**6.0 CERTIFICATION STATEMENT**

"I certify that I believe the information provided in this document is true, accurate, and complete. Results of testing are based on the good faith application of sound professional judgment, using techniques, factors, or standards approved by the Local, State, or Federal Governing body, or generally accepted in the trade."

  
\_\_\_\_\_  
Mr. Thomas Snyder, QSTI

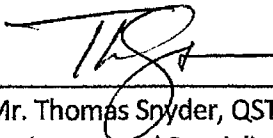
This report prepared by:   
\_\_\_\_\_  
Mr. Thomas Snyder, QSTI  
Environmental Specialist, Field Services Group  
Environmental Management and Resources  
DTE Energy Corporate Services, LLC

This report reviewed by:   
\_\_\_\_\_  
Mr. Mark Grigereit, QSTI  
Principal Engineer, Field Services Group  
Environmental Management and Resources  
DTE Energy Corporate Services, LLC



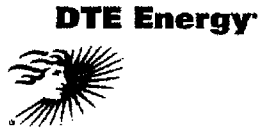

**TABLE NO. 1**  
**HYDROGEN CHLORIDE EMISSIONS TESTING RESULTS**  
**St.Clair Power Plant - Unit 7**  
**May 18, 2018**

Test	Test Date	Test Time	Unit Load (GMW)	DSI Injection Rate (lb/hr)	ACI Injection Rate (lb/hr)	CO <sub>2</sub> Concentration (%)	HCl Concentration (ppmv)	HCl Emissions (lbs/MMBtu) <sup>(1)</sup>
HCl-1	18-May-18	06:47-07:47	297.9	344	56	11.7	<0.19	<0.0003
HCl-2		08:00-09:00	298.1	349	45	11.9	<0.19	<0.0003
HCl-3		09:13-10:13	<u>298.0</u>	<u>332</u>	<u>48</u>	<u>11.9</u>	<0.19	<u>&lt;0.0003</u>
		<b>Average:</b>	<b>298.0</b>	<b>342</b>	<b>50</b>	<b>11.8</b>	<b>&lt;0.19</b>	<b>&lt;0.0003</b>

(1) MATS Limit = 0.002 lb/MMBtu

**RECEIVED**  
**JUN 28 2018**  
**AIR QUALITY DIVISION**



Figure 1 – Sampling Location  
St. Clair Power Plant – Unit 7  
May 18, 2018

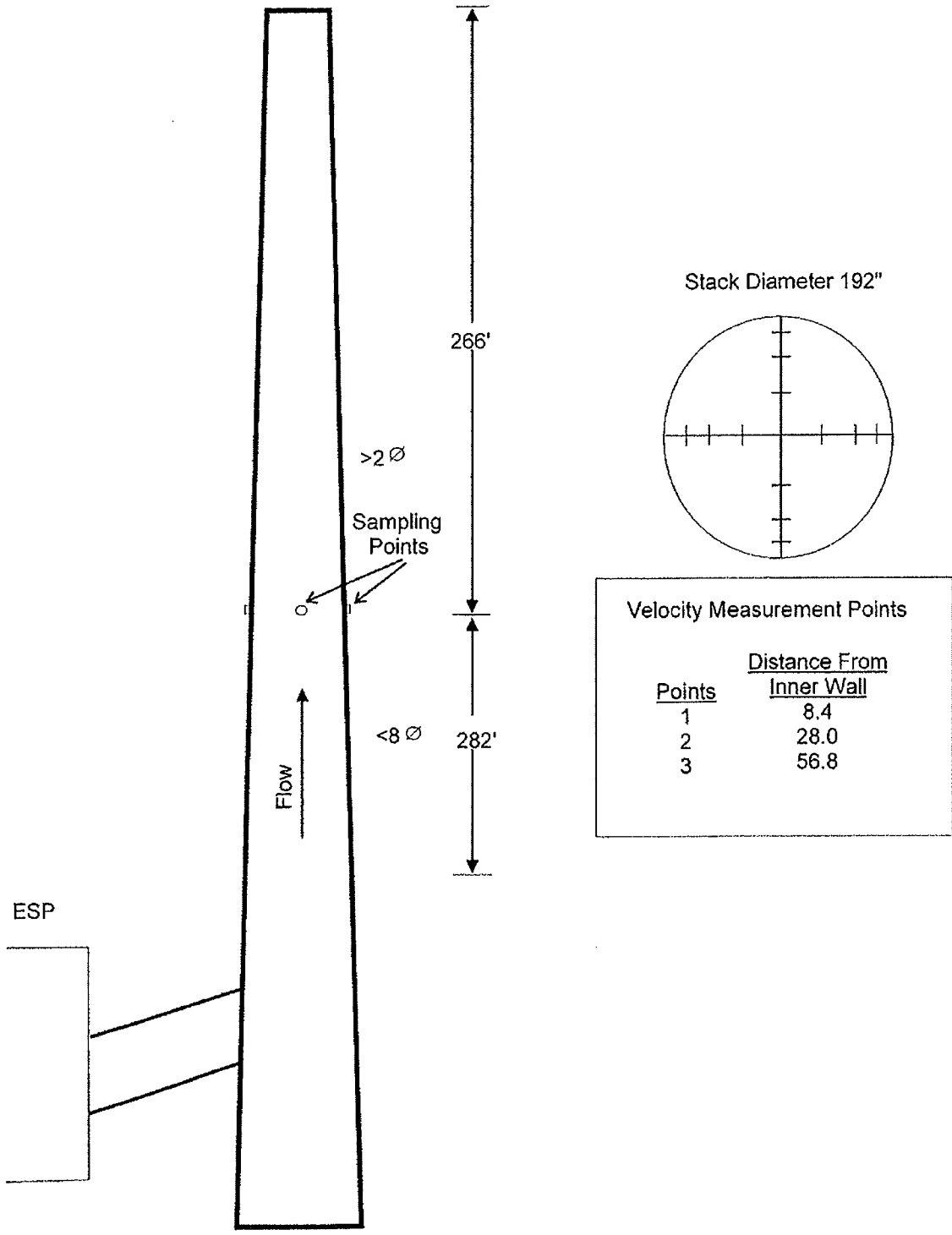



Figure 2 – USEPA Method 26A (Modified)  
St. Clair Power Plant  
May 18, 2018

