

DTE Energy



RECEIVED

DEC 07 2015

AIR QUALITY DIV.

COMPLIANCE TEST REPORT

for

**TOTAL PARTICULATE MATTER (PM), FINE
PARTICULATE MATTER (PM_{10/2.5}) AND
CONDENSABLE PARTICULATE EMISSIONS**

UNIT 2

**St. Clair Power Plant
East China, Michigan**

October 13-15, 2015

Prepared By
Environmental Management & Resources
Environmental Field Services Group
DTE Corporate Services, LLC
7940 Livernois H-136
Detroit, MI 48210



CONTENTS

<u>Section</u>	<u>Page</u>
EXECUTIVE SUMMARY	IV
1.0 INTRODUCTION	1
2.0 SOURCE DESCRIPTION	1
3.0 SAMPLING AND ANALYTICAL PROCEDURES	2
3.1 STACK GAS VELOCITY AND FLOWRATES (USEPA METHODS 1-2)	3
3.1.1 Sampling Method.....	3
3.1.2 Method 2 Sampling Equipment.....	3
3.2 OXYGEN AND CARBON DIOXIDE (USEPA METHOD 3A)	4
3.2.1 Sampling Method.....	4
3.2.2 O ₂ / CO ₂ Sampling Train.....	4
3.2.3 Sampling Train Calibration.....	4
3.3 MOISTURE DETERMINATION (USEPA METHOD 4)	4
3.3.1 Sampling Method.....	4
3.5 PM₁₀ / PM_{2.5} AND CONDENSIBLE PM (USEPA METHODS 201A/202)	6
3.5.1 PM ₁₀ / PM _{2.5} Sampling (Method 201A).....	6
3.5.2 Condensable Particulate Sampling Method (Method 202).....	7
3.5.3 Quality Control and Assurance.....	8
3.5.4 Data Reduction.....	8
4.0 OPERATING PARAMETERS	9
5.0 DISCUSSION OF RESULTS	9
6.0 CERTIFICATION STATEMENT	10

RESULTS TABLES

Table No. 1:..... Particulate Emission Testing Summary – Unit 2



MICHIGAN DEPARTMENT OF ENVIRONMENTAL QUALITY
AIR QUALITY DIVISION

RECEIVED

DEC 07 2015

AIR QUALITY DIV.

**RENEWABLE OPERATING PERMIT
REPORT CERTIFICATION**

Authorized by 1994 P.A. 451, as amended. Failure to provide this information may result in civil and/or criminal penalties.

Reports submitted pursuant to R 336.1213 (Rule 213), subrules (3)(c) and/or (4)(c), of Michigan's Renewable Operating (RO) Permit program must be certified by a responsible official. Additional information regarding the reports and documentation listed below must be kept on file for at least 5 years, as described in General Condition No. 22 in the RO Permit and be made available to the Department of Environmental Quality, Air Quality Division upon request.

Source Name St Clair Power Plant County St. Clair
Source Address 4901 Pointe Drive City East China Township
AQD Source ID (SRN) B2796 RO Permit No. MI-ROP-B2796-2015 RO Permit Section No. 1

Please check the appropriate box(es):

Annual Compliance Certification (General Condition No. 28 and No. 29 of the RO Permit)

Reporting period (provide inclusive dates): From _____ To _____

1. During the entire reporting period, this source was in compliance with ALL terms and conditions contained in the RO Permit, each term and condition of which is identified and included by this reference. The method(s) used to determine compliance is/are the method(s) specified in the RO Permit.

2. During the entire reporting period this source was in compliance with all terms and conditions contained in the RO Permit, each term and condition of which is identified and included by this reference, EXCEPT for the deviations identified on the enclosed deviation report(s). The method used to determine compliance for each term and condition is the method specified in the RO Permit, unless otherwise indicated and described on the enclosed deviation report(s).

Semi-Annual (or More Frequent) Report Certification (General Condition No. 23 of the RO Permit)

Reporting period (provide inclusive dates): From _____ To _____

1. During the entire reporting period, ALL monitoring and associated recordkeeping requirements in the RO Permit were met and no deviations from these requirements or any other terms or conditions occurred.

2. During the entire reporting period, all monitoring and associated recordkeeping requirements in the RO Permit were met and no deviations from these requirements or any other terms or conditions occurred, EXCEPT for the deviations identified on the enclosed deviation report(s).

Other Report Certification

Reporting period (provide inclusive dates): From 10/15/15 To 10/15/18

Additional monitoring reports or other applicable documents required by the RO Permit are attached as described:
ROP Emissions Test Report, EU-BOILER2-SC PM, PM10, PM2.5

I certify that, based on information and belief formed after reasonable inquiry, the statements and information in this report and the supporting enclosures are true, accurate and complete.

<u>Leann S. Warner</u>	<u>Plant Manager</u>	<u>(810) 326-6201</u>
Name of Responsible Official (print or type)	Title	Phone Number
<u>Leann Warner</u>		<u>12-1-15</u>
Signature of Responsible Official		Date

CRYSTAL

1971

MICROFILM



FIGURES

- 1 Sampling Location – Unit 2
- 2 USEPA Method 5B Sampling Train
- 3 USEPA Method 201A/202 Sampling Train

APPENDICES

- A EPA Test Plan and Approval Letter
- B Field Sampling Data
- C Analytical Data
- D Equipment and Analyzer Calibration Data
- E Example Calculations
- F Process Operational Data and Coal Analysis

**EXECUTIVE SUMMARY**

DTE Energy's Environmental Management and Resources (EM&R) Field Services Group performed particulate emissions testing on the exhaust of Unit 2 at the St. Clair Power Plant, located in China Township, Michigan. The testing was required by the Michigan Department of Environmental Quality (MDEQ) Michigan Renewable Operating Permit MI-ROP-B2796-2015 to document total filterable particulate matter (PM), PM₁₀ (particulate matter less than 10 microns diameter), PM_{2.5} (particulate matter less than 2.5 microns diameter), and condensable particulate matter (CPM) stack emissions. The testing was conducted during the period of October 13-15, 2015.

A summary of the emission test results are shown below:

**Emissions Testing Summary
St. Clair Unit 2
October 13-15, 2015**

Source	Filterable PM (lbs/1000 lbs)⁽¹⁾	PM₁₀ (lbs/MMBtu)	PM_{2.5} (lbs/MMBtu)	Condensable PM (lbs/MMBtu)
Unit 2	0.003	0.004	0.002	<0.008

(1) Unit 2 Permit Limit 0.17 lb/1000lbs @ 50% EA



RECEIVED
DEC 07 2015
AIR QUALITY DIV.

1.0 INTRODUCTION

DTE Energy's Environmental Management and Resources (EM&R) Field Services Group performed particulate emissions testing on the exhaust of Unit 2 at the St. Clair Power Plant, located China Township, Michigan. The testing was required by the Michigan Department of Environmental Quality (MDEQ) Michigan Renewable Operating Permit MI-ROP-B2796-2015 to document total filterable particulate matter (PM), PM₁₀ (particulate matter less than 10 microns diameter), PM_{2.5} (particulate matter less than 2.5 microns diameter), and condensable particulate matter (CPM) stack emissions while the unit was operating during normal boiler operating conditions. The testing was conducted during the period of October 13-15, 2015.

Testing was performed pursuant to Title 40, *Code of Federal Regulations*, Part 60, Appendix A (40 CFR §60 App. A), Methods 1, 3, 4, 5B, 201A and 202.

The fieldwork was performed in accordance with EPA Reference Methods and DTE Energy Intent to Test¹, which was approved in a letter by Mr. Thomas Maza from the Michigan Department of Environmental Quality (MDEQ), dated September 16, 2015². The following DTE Energy personnel participated in the testing program: Mr. Mark Grigereit, Principal Engineer, Mr. Thom Snyder, Senior Environmental Technician, and Mr. Fred Meinecke, Senior Environmental Technician. Mr. Grigereit was the project leader. Mr. Joe neruda, Senior Environmental Specialist at the plant provided process coordination for the testing program.

2.0 SOURCE DESCRIPTION

The St Clair Power Plant (SCPP) located at 4901 Pointe Drive in East East China, Michigan, employs the use of six (6) coal-fired boilers (Units 1-4, 6, and 7). Units 1-4 each have Babcock and Wilcox boilers capable of producing 1,070,000 pounds per hour of steam. Units 1 and 4 are equipped with General Electric turbine generators each with a nominally rated capability of 167 megawatts (MW). Units 2 and 3 have Allis Chalmers turbine generators each with a nominally rated capability of 170 MW. Full load capability for Units 1-4, while firing coal only, is 135 MW, and 150 MW while over-firing with oil.

Units 6 and 7 have Combustion Engineering boilers capable of producing 2,100,000 and 3,580,000 pounds of steam per hour respectively. The turbine generators on each unit were manufactured by Westinghouse and have a nominally rated capability of 325 and 500

¹ MDEQ, Test Plan, Submitted August 26, 2015. (Attached-Appendix A)

² MDEQ, Approval Letter, dated October 16, 2015. (Attached-Appendix A)



RECEIVED
MAY 11 2011
MICHIGAN DEPT. OF ENVIRONMENTAL
ENERGY & LIAISON

megawatts respectively. Full load capability for Units 6 and 7 while firing coal only is approximately 315 MW and 470 MW respectively.

The air pollution control equipment on Units 1-4 consists of Wheelabrator Frye electrostatic precipitators on each unit that have design collection efficiencies of 99.6%. Each exhaust stack is 599 feet tall with an internal diameter of 13.3 feet. The air pollution control equipment on Unit 6 consists of Research Corporation electrostatic precipitators that have design collection efficiencies of 99.6%. The exhaust stack is 425 feet tall with an internal diameter of 19.0 feet. The air pollution control equipment on Unit 7 consists of an American Standard electrostatic precipitator that has design collection efficiency of 99.6%. The exhaust stack is 600 feet tall with an internal diameter of 16.0 feet

The air pollution control equipment on Unit 2 consists of Wheelabrator Frye electrostatic precipitators on each unit that have design collection efficiencies of 99.6%. Each exhaust stack is 599 feet tall with an internal diameter of 13.3 feet. The air pollution control equipment on Unit 6 consists of Research Corporation electrostatic precipitators that have design collection efficiencies of 99.6%. The exhaust stack is 425 feet tall with an internal diameter of 19.0 feet. The air pollution control equipment on Unit 7 consists of an American Standard electrostatic precipitator that has design collection efficiency of 99.6%. The exhaust stack is 600 feet tall with an internal diameter of 16.0 feet

Testing occurred on Unit 2 at greater than 80% of normal full load capability while burning coal.

3.0 SAMPLING AND ANALYTICAL PROCEDURES

DTE Energy obtained emissions measurements in accordance with procedures specified in the USEPA *Standards of Performance for New Stationary Sources* or listed as an approved "Other Test Method". The sampling and analytical methods used in the testing program are indicated in the table below:



Sampling Method	Parameter	Analysis
USEPA Methods 1-2	Exhaust Gas Flow Rates	Field data analysis and reduction
USEPA Method 3A	Oxygen & CO ₂	Instrumental Analyzer Method
USEPA Method 4	Moisture Content	Field data analysis and reduction
USEPA Method 5B	Filterable Particulate Matter (Non-Sulfuric Acid)	Gravimetric Analysis
USEPA Method 201A	PM _{10/2.5}	Gravimetric Analysis
USEPA Method 202	Condensable Particulate Matter	Gravimetric Analysis

3.1 STACK GAS VELOCITY AND FLOWRATES (USEPA Methods 1-2)

3.1.1 Sampling Method

Stack gas velocity traverses were conducted in accordance with the procedures outlined in USEPA Method 1, "Sample and Velocity Traverses for Stationary Sources," and Method 2, "Determination of Stack Gas Velocity and Volumetric Flowrate." Four (4) sampling ports were utilized, sampling at three (3) points per port for a total of twelve (12) sampling points. See Figure 1 for a diagram of the traverse/sampling points used.

A cyclonic flow check was performed during Unit 2's initial flow monitor certification RATA. Testing at the sampling location demonstrated that no cyclonic flow was present. No changes to the stack have occurred since the cyclonic flow check was performed. Additionally, static pressure checks performed each day confirmed that the null angles were at 0°.

3.1.2 Method 2 Sampling Equipment

The EPA Method 2 sampling equipment consisted of a 0-10" incline manometer, calibrated S-type pitot tubes ($C_p = 0.84$ & 0.765) and a type-K calibrated thermocouple.

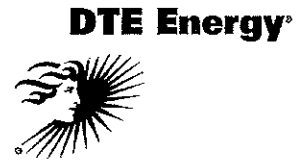

3.2 OXYGEN AND CARBON DIOXIDE (USEPA Method 3A)

3.2.1 Sampling Method

Stack gas Oxygen (O₂) and Carbon Dioxide (CO₂) emissions were evaluated using USEPA Method 3A, "Gas Analysis for Carbon Dioxide, Oxygen, Excess Air, and Dry Molecular Weight (Instrumental Analyzer Method)". The O₂ / CO₂ analyzers utilize paramagnetic sensors.

3.2.2 O₂/CO₂ Sampling Train

On Unit 2 the Method 3A sampling system consisted of collecting an integrated dry gas sample in a Tedlar bag during each test. The Tedlar bag was then analyzed using a Servomex 1400 O₂/CO₂ gas analyzer.

3.2.3 Sampling Train Calibration

The O₂ / CO₂ analyzer was calibrated according to procedures outlined in USEPA Method 7E. Zero, span, and mid range calibration gases were introduced directly into the analyzer to verify the instruments linearity. The O₂/CO₂ concentrations were recorded on the field data sheets.

3.3 MOISTURE DETERMINATION (USEPA Method 4)

3.3.1 Sampling Method

Determination of the moisture content of the exhaust gas was performed using the method described in USEPA Method 4, "Determination of Moisture Content in Stack Gases". The moisture was collected in glass impingers and the percentage of moisture was then derived from calculations outlined in USEPA Method 4.

3.4 PARTICULATE MATTER (USEPA Method 5B)

3.4.1 Filterable Particulate Sampling Method

USEPA Method 5B, "Determination of Non-Sulfuric Acid Particulate Emissions from Stationary Sources" was used to measure the filterable (front-half) particulate emissions (see Figure 3 for a schematic of the sampling train). Triplicate, 60-minute test runs were conducted.

The Method 5B modular isokinetic stack sampling system consisted of the following:

- (1) PTFE coated stainless-steel button-hook nozzle
- (2) Heated glass-lined probe



- (3) Heated 3" glass filter holder with a quartz filter (maintained at a temperature of 320 ± 25 °F)
- (4) Set of impingers for the collection of condensate for moisture determination
- (5) Length of sample line
- (6) Environmental Supply[®] control case equipped with a pump, dry gas meter, and calibrated orifice.

The quartz filters used in the sampling were initially baked for 3 hours at 320 °F, desiccated for 24 hours and weighed to a constant weight as described in Method 5B to obtain the initial tare weight.

After completion of the final leak test for each test run, the filter was recovered, and the probe, nozzle and the front half of the filter holder assembly were brushed and rinsed with acetone. The acetone rinses were collected in a pre-cleaned sample container. The container was labeled with the test number, test location, test date, and the level of liquid marked on the outside of the container. Immediately after recovery, the sample containers were placed in a cooler for storage.

At the laboratory the acetone rinses were transferred to clean pre-weighed beakers, and evaporated to dryness at ambient temperature and pressure. The beakers and filters were baked for 6 hours at 320 °F, desiccated for 24 hours and weighed to a constant weight (within 0.5 mg). The data sheets containing the initial and final weights on the filters and beakers can be found in Appendix C.

Collected field blanks consisted of a blank filter and acetone solution blank. The acetone blank was collected from the rinse bottle used in sample recovery. The blank filter and acetone were collected and analyzed following the same procedures used to recover and analyze the field samples. Field data sheets for the Method 5B sampling can be found in Appendix B.

3.4.2 Quality Control and Assurance

All sampling and analytical equipment was calibrated according to the guidelines referenced in EPA Method 5B. All Method 1-4, and 5B calibration data is located in Appendix D.

3.4.3 Data Reduction

The filterable PM emissions data collected during the testing was calculated and reported as lb/1000lbs @ 50% excess air.



3.5 PM_{10} / $PM_{2.5}$ and CONDENSIBLE PM (USEPA METHODS 201A/202)

3.5.1 PM_{10} / $PM_{2.5}$ Sampling (Method 201A)

USEPA "Method 201A, "Determination of PM_{10} and $PM_{2.5}$ Emissions from Stationary Sources" was used to measure the PM_{10} / $PM_{2.5}$ emissions on Unit 2 (see Figure 3 for a schematic of the sampling train). Triplicate, 120-minute test runs were conducted.

The Method 201A sampling train consisted of the following:

- (1) PM_{10} Cyclone with nozzle followed by a $PM_{2.5}$ cyclone
- (2) 47 mm quartz filter capable of capturing 0.3um size particulate
- (3) Stainless steel probe with glass liner with attached s-type pitot tube and Type K thermocouple
- (4) Method 202 glassware
- (5) Method 5 umbilical and meter box.

Prior to performing each test run the entire sampling train was leak checked. At the completion of each test the cyclone was removed and a final leak was performed at the outlet of the probe. After the cyclone cooled, it was disassembled two sections of the cyclone were rinsed with acetone and the filter was placed into a Petri dish which was sealed. The collected fractions were as follows:

- (1) PM between 10 and 2.5 microns – back half of PM_{10} cyclone and front half of $PM_{2.5}$ Cyclone
- (2) PM <2.5 microns – Back half of $PM_{2.5}$ cyclone and 47mm filter.

The acetone rinses were collected into pre-cleaned sample containers. The containers were labeled with the test number, sample fraction, test location, test date, and the level of liquid marked on the outside of the container. Immediately after recovery, the sample containers were placed in a cooler for storage.

At the laboratory the acetone rinses were transferred to clean pre-weighed beakers, and evaporated to dryness at ambient temperature and pressure. The beakers and filters were then desiccated for 24 hours and weighed to a constant weight. The data sheets containing the initial and final weights on the filters and beakers can be found in Appendix C.

Collected field blanks consisted of a blank filter and acetone solution blank. The acetone blank was collected from the rinse bottle used in sample recovery. The blank filter and acetone were collected and analyzed following the same procedures used to recover and analyze the field samples.



3.5.2 Condensable Particulate Sampling Method (Method 202)

USEPA Method 202, "Dry Impinger method for Determining Condensable Particulate Emissions from Stationary Sources" was used to measure the condensable particulate matter (CPM). This method includes procedures for measuring both organic and inorganic CPM. The Method 202 samples were collected in conjunction with the Method 201A samples.

The Method 202 impinger configuration (Figure 3 – after the Method 201A cyclone assembly,) consisted of the following:

- (1) Method 23 type condenser (capable of cooling the stack gas to less than 85 °F)
- (2) Condensate dropout impinger (dry) without the bubbler tube
- (3) Modified Greenburg-Smith impinger (dry) with no taper as a backup impinger
- (4) 3" glass filter holder with a PTFE filter (maintained at a temperature \leq 85 °F)
- (5) Modified Greenburg-Smith impinger containing 100 millimeters (ml) of distilled de-ionized (DDI) water
- (6) Modified Greenburg-Smith impinger containing approximately 300 grams of silica gel desiccant.

The condensate dropout impinger and backup impinger were placed in an insulated box with water at \leq 85 °F. The water and silica gel impingers were placed in an ice water bath to maintain the exit gas temperature from the silica gel impinger below 68°F.

All Method 202 glassware was pre-cleaned prior to testing with soap and water, and rinsed using tap water, distilled de-ionized (DDI) water, acetone, and finally, hexane. After cleaning, the glassware was baked at 300 °C for 6 hours. Prior to each sampling run, the train glassware was rinsed thoroughly with distilled deionized ultra-filtered water.

As soon as possible after the post-test leak check was completed, the Method 201A/Method 5 probe and heated filter box was detached from the Method 202 condenser and impinger train. The Method 202 impinger train was then carefully disassembled. The liquid volume of each impinger was measured (by weight) and recorded on the field data sheet. The silica gel was re-weighed, and any increase was recorded on the field data sheets. Moisture from the condensate dropout impinger was added to the second impinger. The Method 202 impinger train was purged with ultra-high purity compressed nitrogen at 14 liters per minute for 60 minutes. During the purge the condenser recirculation pump was operated and the first two impingers



were heated/cooled to maintain the gas temperature exiting the CPM filter below 85 °F.

Contents from the dropout impinger and the impinger prior to the CPM filter were collected into a pre-cleaned sample container. The condenser, impingers and front-half of the CPM filter holder were rinsed with DDI water and the rinses added to the sample container. The condenser, impingers and front-half of the CPM filter holder were then rinsed with acetone followed by two rinses with hexane. The acetone and hexane rinses were collected into a pre-cleaned sample container. The CPM filter was recovered and placed into a labeled container. All containers were labeled with the test number, test location, test date, and the level of liquid marked on the outside of the container. Immediately after recovery, the sample containers were placed in a cooler for storage.

Collected blanks consisted of an acetone rinse blank, a DDI water rinse blank and a hexane rinse blank taken directly from the bottles used during recovery of the samples. Additionally, a field train blank was assembled and recovered following the same procedures used to prepare and recover the test samples.

Analysis of the Method 202 samples and blanks were conducted by Maxxam Analytics of Mississauga, Ontario. All analysis followed the procedures listed in Method 202. A complete laboratory report can be found in Appendix C. Blank corrections were applied to the samples following the procedures outlined in Method 202 (correcting the samples by less than or equal to 2.0 mg).

Field data sheets for the Method 201A/Method 202 sampling can be found in Appendix B.

3.5.3 Quality Control and Assurance

All sampling and analytical equipment was calibrated according to the guidelines referenced in EPA Methods 201A/202.

3.5.4 Data Reduction

PM_{10/2.5} sampling was performed utilizing Environmental Supply Company software. Emission rates were calculated utilizing this software as well. Emissions data collected during the emissions testing was reported as grains per dry standard cubic foot (grains/dscf) and pounds per hour (lb/hr) and pounds per million British thermal unit (lbs/MMBtu).



4.0 OPERATING PARAMETERS

The test program included the collection of boiler load and stack emissions CEMs data during each test run. Parameters recorded included gross Megawatts (MW) and CEMs data (SO₂, NO_x, CO₂, and Opacity).

Process data collected from each Unit's digital control system included load in gross megawatts (MW), main steam flow in thousand pounds per hour (Klbs/hr), coal flow in tons per hour (Tons/hr), and total precipitator power in kilowatts (kW).

Coal samples were collected during each day of sampling and subject to proximate and ultimate analysis.

Operational data and results of the fuel analysis can be referred to in Appendix F.

5.0 DISCUSSION OF RESULTS

Table 1 presents the Particulate Emission testing results from Unit 2. Particulate (Total Filterable, PM₁₀, PM_{2.5}, and Condensable PM) emissions are presented in grain per dry standard cubic foot (gr/DSCF), pounds per hour (lbs/hr) and pounds per 1000 pounds @ 50% excess air (lbs/1000lbs @ 50% excess air). Additional test data presented for each test includes the Unit load in gross megawatts (GMW), stack temperature in degrees Fahrenheit (°F), stack gas velocity in feet per minute (ft/min), and stack gas flow rate in actual cubic feet per minute (ACFM), standard cubic feet per minute (SCFM) and dry standard cubic feet per minute (DSCFM). The average filterable PM emissions from Unit 2 were 0.003 lbs/1000lbs @ 50% excess air which was less than the permit limit of 0.17 lbs/1000lbs excess air.

The average PM₁₀, PM_{2.5}, and Condensable PM emissions were 0.004, 0.002, and <0.008 lbs/MMBtu, respectively.



6.0 CERTIFICATION STATEMENT

"I certify that I believe the information provided in this document is true, accurate, and complete. Results of testing are based on the good faith application of sound professional judgment, using techniques, factors, or standards approved by the Local, State, or Federal Governing body, or generally accepted in the trade."



Mr. Mark R. Grigereit, QSTI

This report prepared by: 

Mr. Mark R. Grigereit, QSTI
Principal Engineer, Field Services
Environmental Management and Resources
DTE Energy Corporate Services, LLC

This report reviewed by: 

Mr. Thomas Snyder, QSTI
Senior Environmental Technician, Field Services Group
Environmental Management and Resources
DTE Energy Corporate Services, LLC

DTE Energy



RESULTS TABLE



Table No. 1
PARTICULATE EMISSION TESTING SUMMARY
St. Clair Power Plant - Unit 2
October 13-15, 2015

Unit 2 - Total Filterable PM

Test	Test Date	Test Time	Unit Load (GMW)	Stack Temperature (°F)	Stack Velocity (ft/min)	Exhaust Gas Flowrates			PM Emissions		
						(ACFM)	(SCFM)	(DSCFM)	(grains/dscf)	(lbs/hr)	(lbs/1000lbs @ 50% EA) ⁽¹⁾
PM-1	13-Oct-15	6:50-7:55	129.5	268	5,556	775,721	548,174	514,517	0.001	5.3	0.004
PM-2		8:30-9:34	129.1	268	5,496	767,326	541,870	509,670	0.001	4.8	0.003
PM-3		10:00-11:08	<u>129.2</u>	<u>268</u>	<u>5,563</u>	<u>776,793</u>	<u>549,183</u>	<u>516,583</u>	<u>0.001</u>	<u>4.8</u>	<u>0.003</u>
<i>Average:</i>			129.3	268	5,538	773,280	546,409	513,590	0.001	5.0	0.003

(1) Permit Limit = 0.17 lbs/1000 lbs @ 50% excess air

Unit 2 - PM10

Test	Test Date	Test Time	Unit Load (GMW)	Stack Temperature (°F)	Stack Velocity (ft/min)	Exhaust Gas Flowrates		PM10 Emissions		
						(SCFM)	(DSCFM)	(grains/dscf)	(lbs/hr)	(lbs/MMBtu)
PM10 - 1	14-Oct-15	11:10-13:19	130.1	272	5,491.5	544,732	517,485	0.0016	7.04	0.004
PM10 - 2	14-Oct-15	13:43-15:49	129.8	274	5,298.5	525,546	499,669	0.0016	7.06	0.004
PM10 - 3	15-Oct-15	7:13-10:04	<u>114.2</u>	<u>261</u>	<u>5,211.5</u>	<u>526,468</u>	<u>499,126</u>	<u>0.0015</u>	<u>6.33</u>	<u>0.004</u>
<i>Average:</i>			124.7	269	5,333.9	532,249	505,427	0.0016	6.81	0.004

Unit 2 - PM2.5

Test	Test Date	Test Time	Unit Load (GMW)	Stack Temperature (°F)	Stack Velocity (ft/min)	Exhaust Gas Flowrates		PM2.5 Emissions		
						(SCFM)	(DSCFM)	(grains/dscf)	(lbs/hr)	(lbs/MMBtu)
PM10 - 1	14-Oct-15	11:10-13:19	130.1	272	5,491.5	544,732	517,485	0.0007	2.97	0.002
PM10 - 2	14-Oct-15	13:43-15:49	129.8	274	5,298.5	525,546	499,669	0.0007	2.98	0.002
PM10 - 3	15-Oct-15	7:13-10:04	<u>114.2</u>	<u>261</u>	<u>5,211.5</u>	<u>526,468</u>	<u>499,126</u>	<u>0.0006</u>	<u>2.37</u>	<u>0.001</u>
<i>Average:</i>			124.7	269	5,333.9	532,249	505,427	0.0007	2.77	0.002

Unit 2 - Condensibles

Test	Test Date	Test Time	Unit Load (GMW)	Stack Temperature (°F)	Stack Velocity (ft/min)	Exhaust Gas Flowrates		Condensibile PM Emissions		
						(SCFM)	(DSCFM)	(grains/dscf)	(lbs/hr)	(lbs/MMBtu)
PM10 - 1	14-Oct-15	11:10-13:19	130.1	272	5,491.5	544,732	517,485	<0.0035	<15.64	<0.009
PM10 - 2	14-Oct-15	13:43-15:49	129.8	274	5,298.5	525,546	499,669	<0.0021	<8.94	<0.005
PM10 - 3	15-Oct-15	7:13-10:04	<u>114.2</u>	<u>261</u>	<u>5,211.5</u>	<u>526,468</u>	<u>499,126</u>	<u>0.0039</u>	<u>16.61</u>	<u>0.009</u>
<i>Average:</i>			124.7	269	5,333.9	532,249	505,427	<0.0032	<13.7300	<0.008



FIGURES



Figure 1 – Sampling Location & Traverse Points
St Clair Power Plant – Units 1-4
October 13-15, 2015

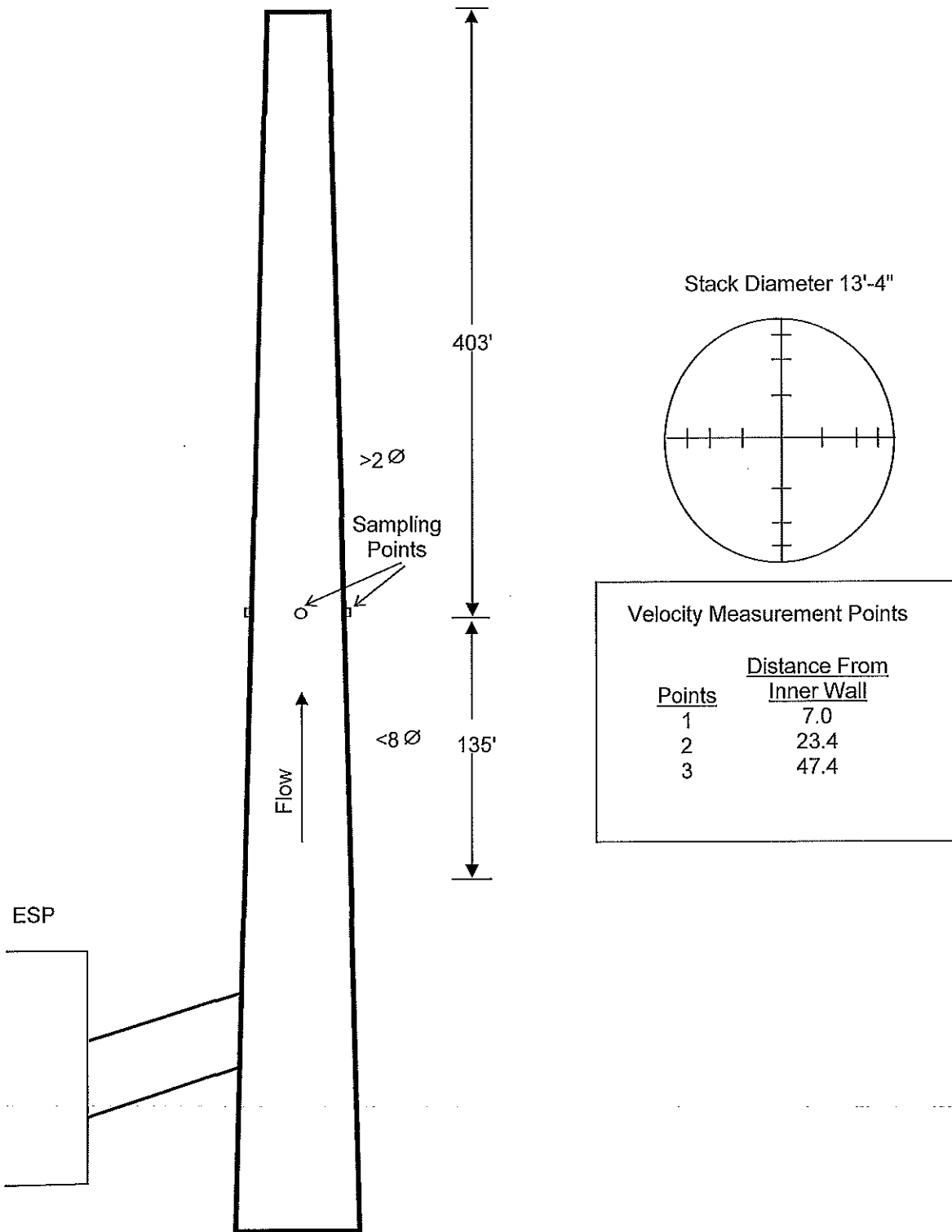



Figure 2– EPA Method 5B
St Clair Power Plant
October 13-15, 2015

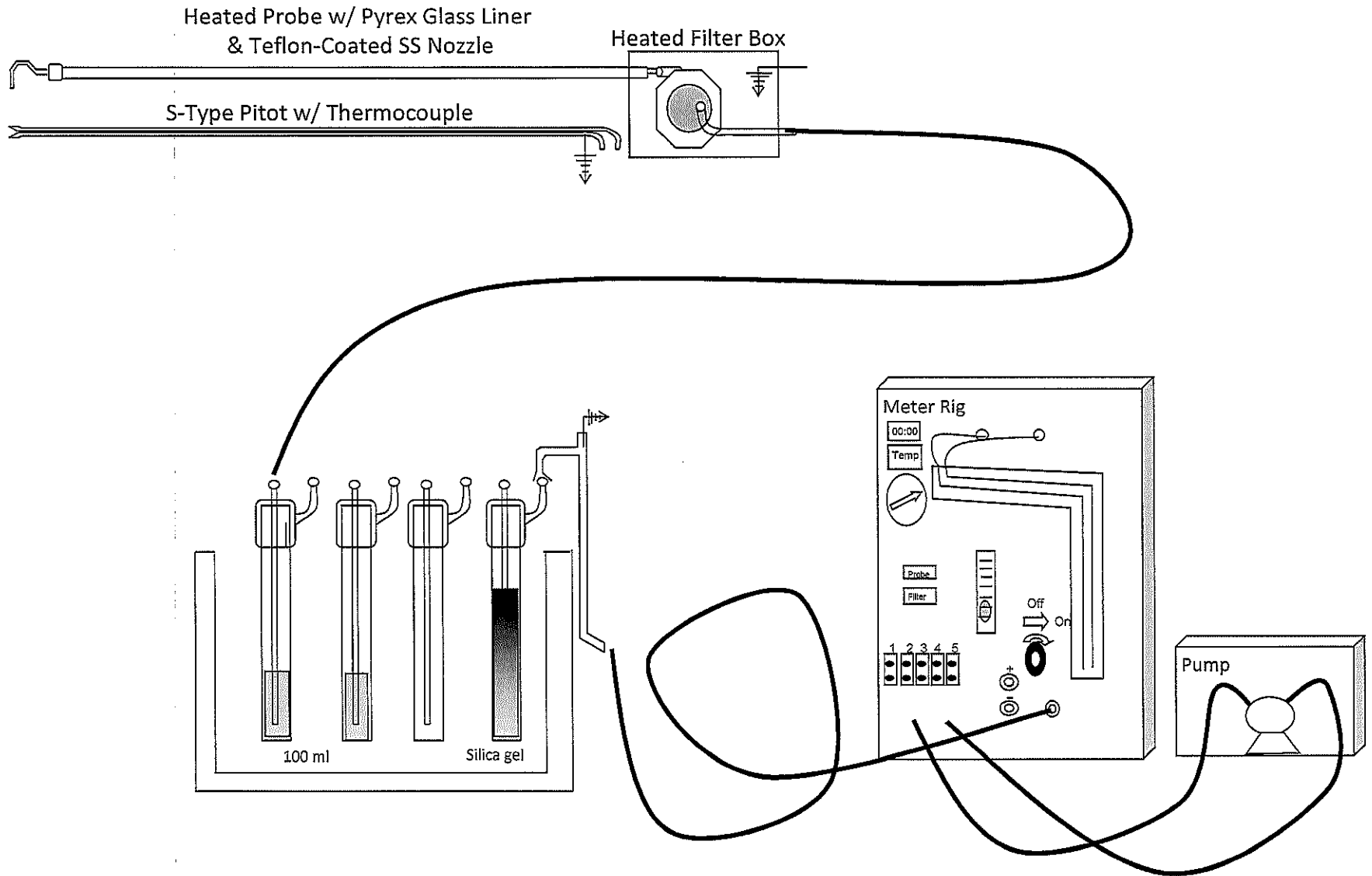



Figure 3 –Methods 201a & 202
St Clair Power Plant
October 13-15, 2015

